

# **X-ray Surveyor: Science drivers and strawman mission design**

A. Vikhlinin (SAO), M. Weisskopf (MSFC), J. Gaskin (MSFC), H. Tananbaum (SAO),  
on behalf of the X-ray Surveyor community

PhysPAG executive committee telecon  
June 8, 2015

# X-ray Surveyor Science Workshop



October 6-8 2015, Washington, DC,  
National Museum of the American Indian

SOC: J. Gaskin, M. Weisskopf (MSFC),  
H. Tananbaum, A. Vikhlinin, G. Fabbiano,  
C. Jones (SAO), E. Feigelson, W. N. Brandt,  
L. Townsley, D. Burrows (PSU), P. Natarajan  
(Yale), M. Markevitch (GSFC), A. Kravtsov  
(Chicago), S. Allen, R. Romani (Stanford),  
S. Heinz (Wisconsin), C. Kouveliotou  
(GWU), F. Ozel (Ariz.), R. Mushotzky (UMD),  
M. Nowak (MIT), R. Osten (STSCI)

# Mission concept developed by the MSFC Advanced Concepts Office

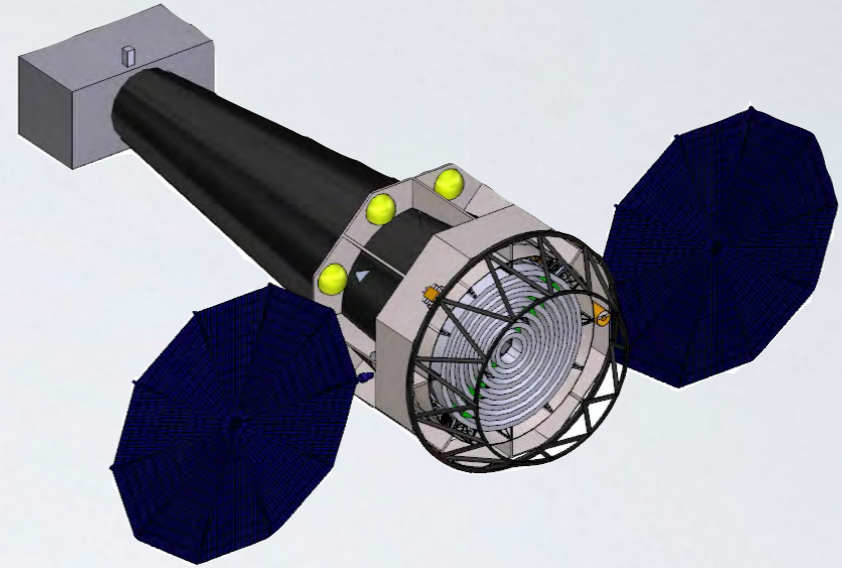

Strawman payload definition: Structures, Thermal control,  
Mechanisms, Propulsion, Guidance, navigation & control, Avionics,  
Power, Orbit trade & launch vehicle, Radiation environments, Initial  
cost estimates.

under the guidance of informal mission concept team:  
M. Weisskopf, J. Gaskin, B. Ramsey, Steve O'Dell (MSFC),  
A. Vikhlinin, H. Tananbaum, P. Reid, D. Schwartz, R. Kraft (SAO),  
D. Burrows, A. Falcone, L. Townsley (PSU), M. Bautz, R. Heilmann  
(MIT), S. Bandler, A. Ptak, R. Petre, C. Kilbourne (GSFC),  
R. McEntaffer (Iowa), F. Harrison (Caltech), A. Kravtsov (Chicago),  
P. Natarajan (Yale), S. Heinz (Wisconsin), C. Kouveliotou (GWU)

M.Weisskopf will present results at the special AAS/HEAD meeting  
in Chicago on June 29 – July 1.

# X-ray Surveyor capabilities: Sensitivity & field of view

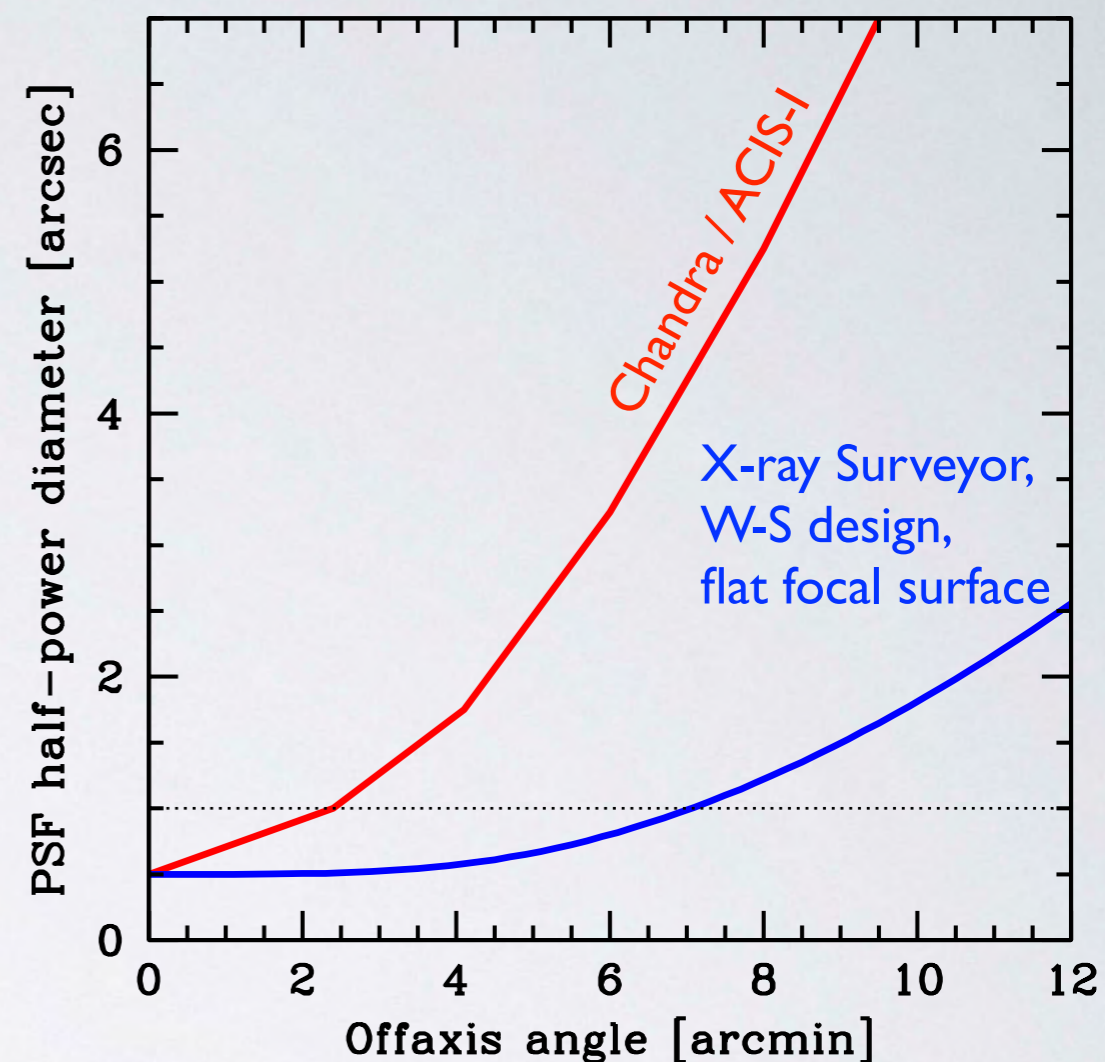
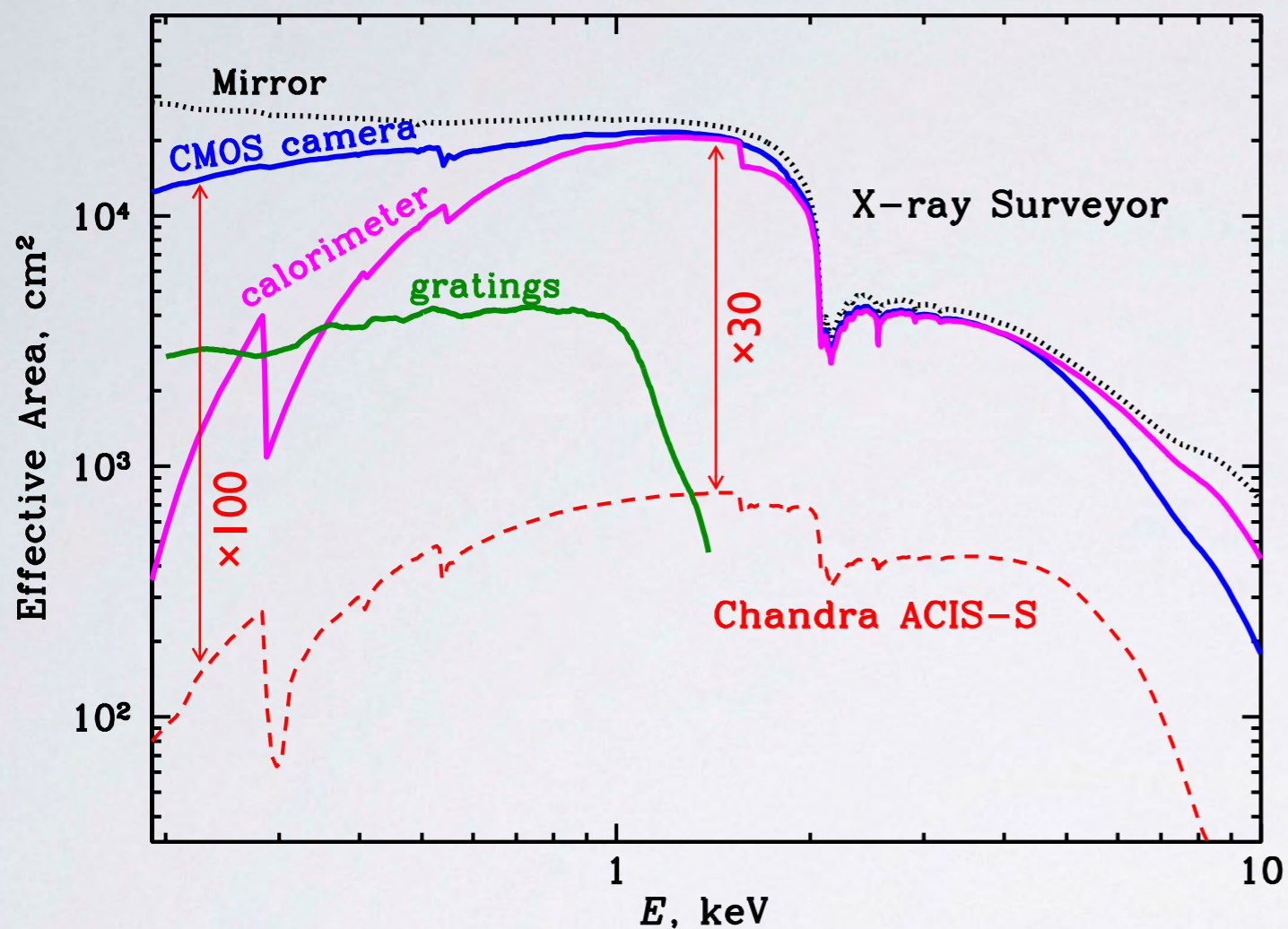

- ×50 more effective area than *Chandra* (due to mirror & QE improvements)
- Neither background nor confusion-limited for PSF better than ~1" HPD, so sensitivity is proportional to area. 4 Msec *Chandra* Deep Field done in 80 ksec. 4 Msec detection limit is  $\sim 1 \times 10^{-19}$  erg/s/cm<sup>2</sup> (0.5–2 keV band)
- ×10 larger solid angle for sub-arcsec imaging with shorter mirrors and Wolter-Schwarzschild optical scheme
- **×500 higher survey speed**

# *X-ray Surveyor Capabilities: Spatially resolved spectroscopy*

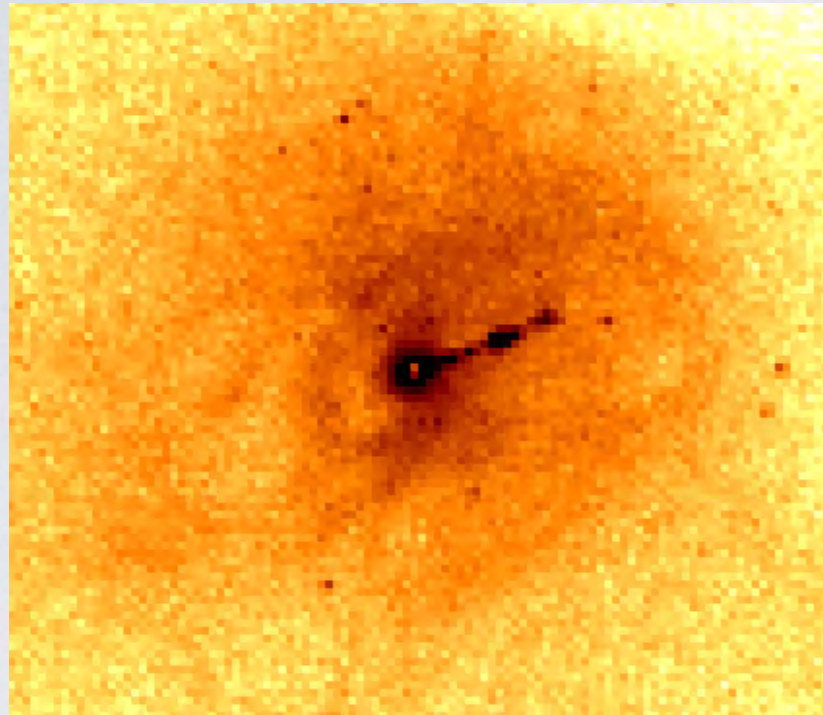

Chandra image of M87: jet from the central supermassive black hole interacts with intracluster medium.

1 pixel = 1" = 90pc

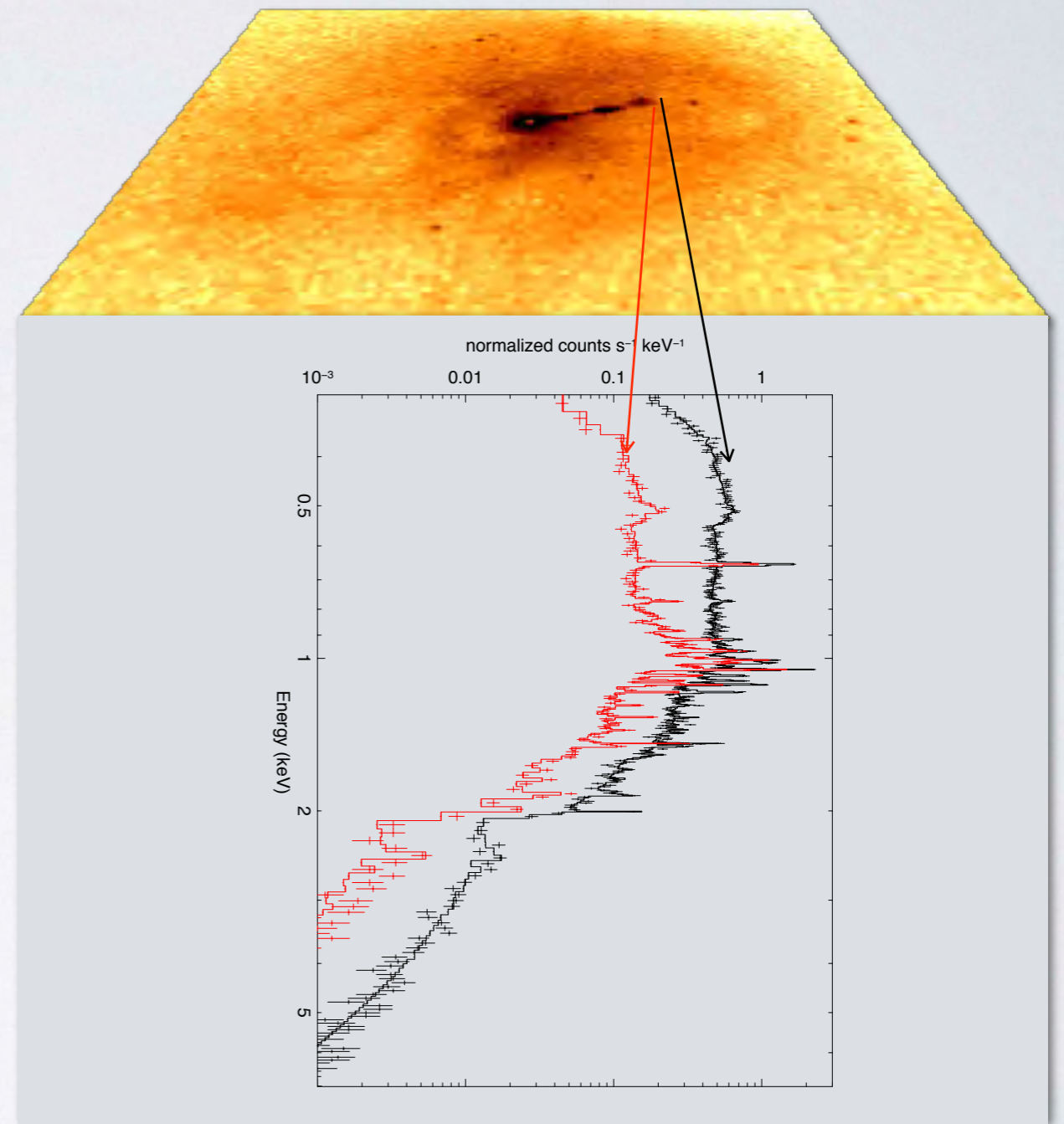

**X-ray Surveyor will add 3rd dimension to the data (chemistry, kinematics)**

# ***X-ray Surveyor Capabilities: High-resolution spectroscopy***

- Recent technological advances improve grating efficiency to  $\sim 0.5$  in the soft X-ray band
- X-ray Surveyor can accommodate insertable gratings with  $R=5000$  and effective area  $\sim 4,000 \text{ cm}^2$
- This is a factor of  $\sim 250$  improvement in throughput and 5–10 in resolving power over the current state-of-the-art

Off-plane reflection gratings concept  
*Credit: R. McEntaffer*

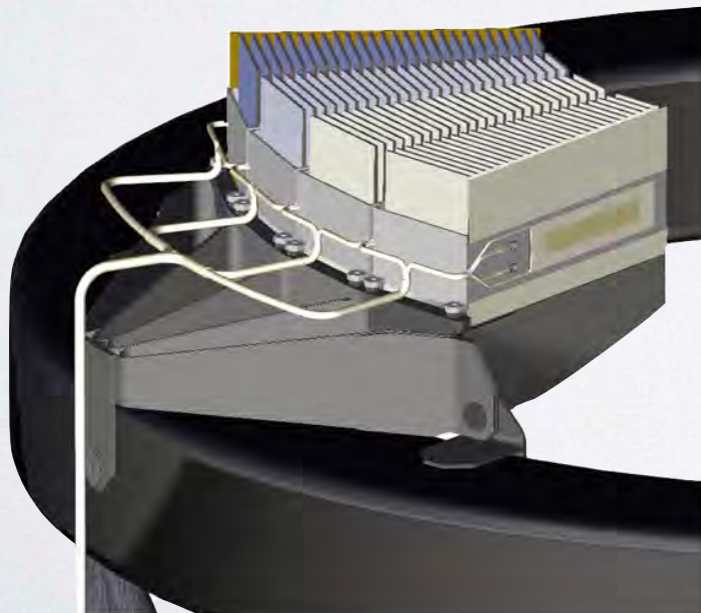

Critical-angle transmission gratings concept  
*Credit: R. Heilmann*

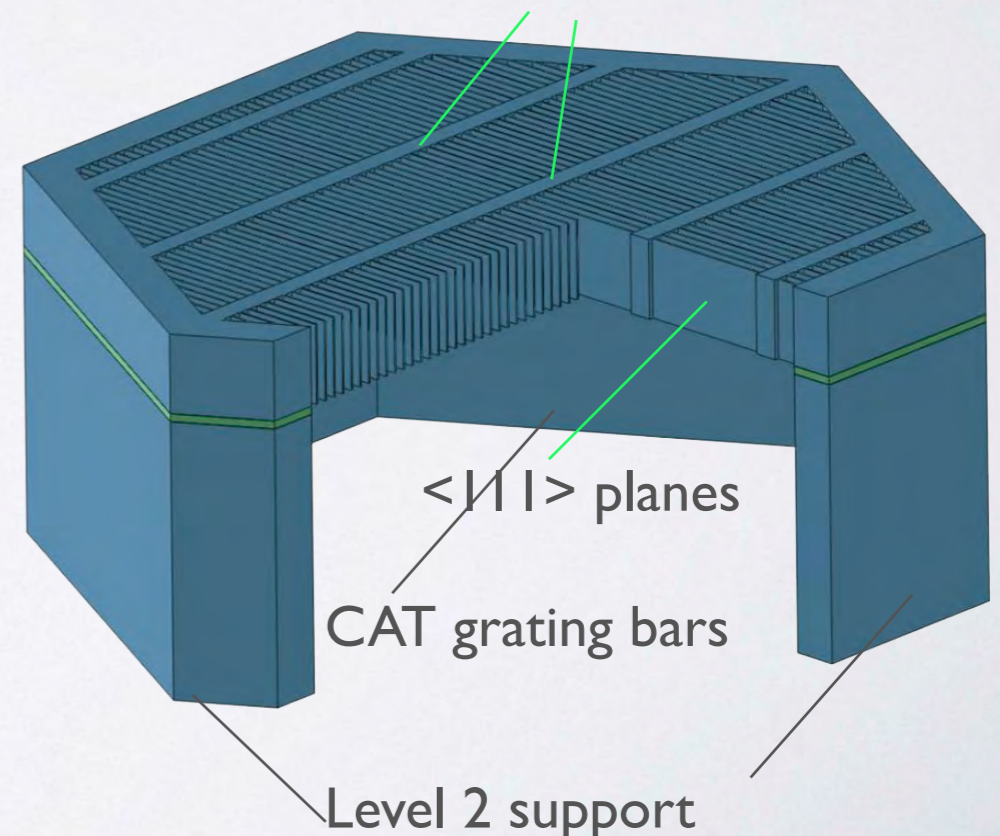

# First generations of supermassive black holes

- Age of the Universe at  $z=6$  is barely enough for quasars with  $M_{\text{BH}} > 10^9 M_{\text{Sun}}$  to grow via accretion. Likely, quick violent formation of massive seeds, followed by fast accretion.
- Lower-mass black holes,  $M_{\text{BH}} < 10^6 M_{\text{Sun}}$ , are best observed in X-rays:
  - Spectral peak ( $\lambda_{\text{max}} \sim M_{\text{BH}}^{1/4}$ ) shifts towards X-ray band, reducing optical/UV output.
  - Dust obscuration impacts optical/UV. Common IR signatures of obscured AGNs are redshifted out of JWST band at  $z=10$ .
  - For small seeds,  $L_{\text{opt,AGN}} < L_{\text{gal}}$
  - X-ray emission is direct probe of accretion, the primary black hole growth channel

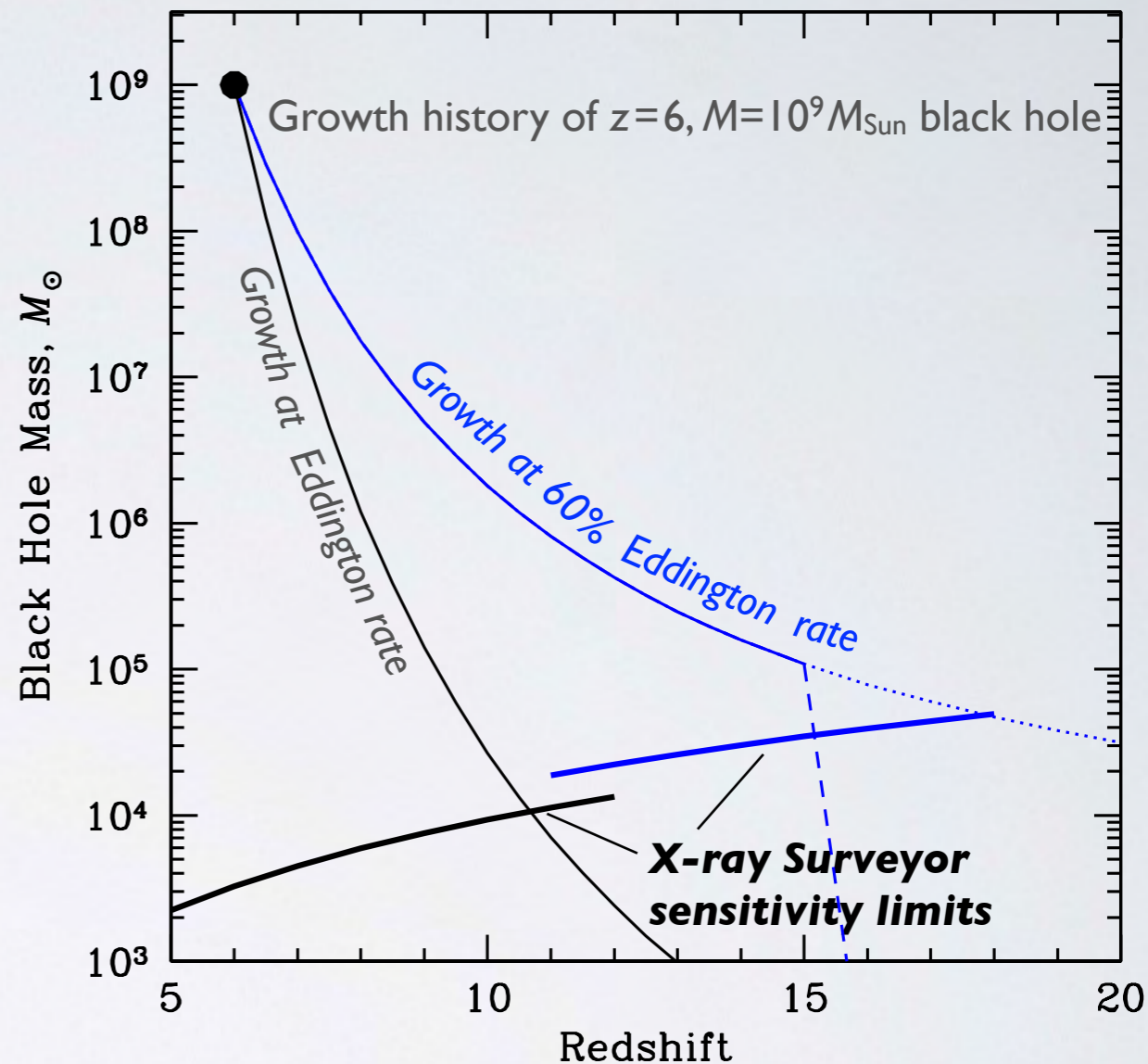

- X-ray Surveyor will detect *first accretion light in the Universe*: unobscured hard X-rays,  $E > 2$  keV in rest frame, from hot accretion disk coronae ( $\sim 10\%$  of  $L_{\text{bol}}$ ) at  $z=10$  from Eddington-accreting black holes with  $M_{\text{BH}} \sim 10,000 M_{\text{Sun}}$

# Angular resolution requirements for detecting first accretion light

Simulated 2x2 arcmin deep fields observed with JWST, X-ray Surveyor, and ATHENA

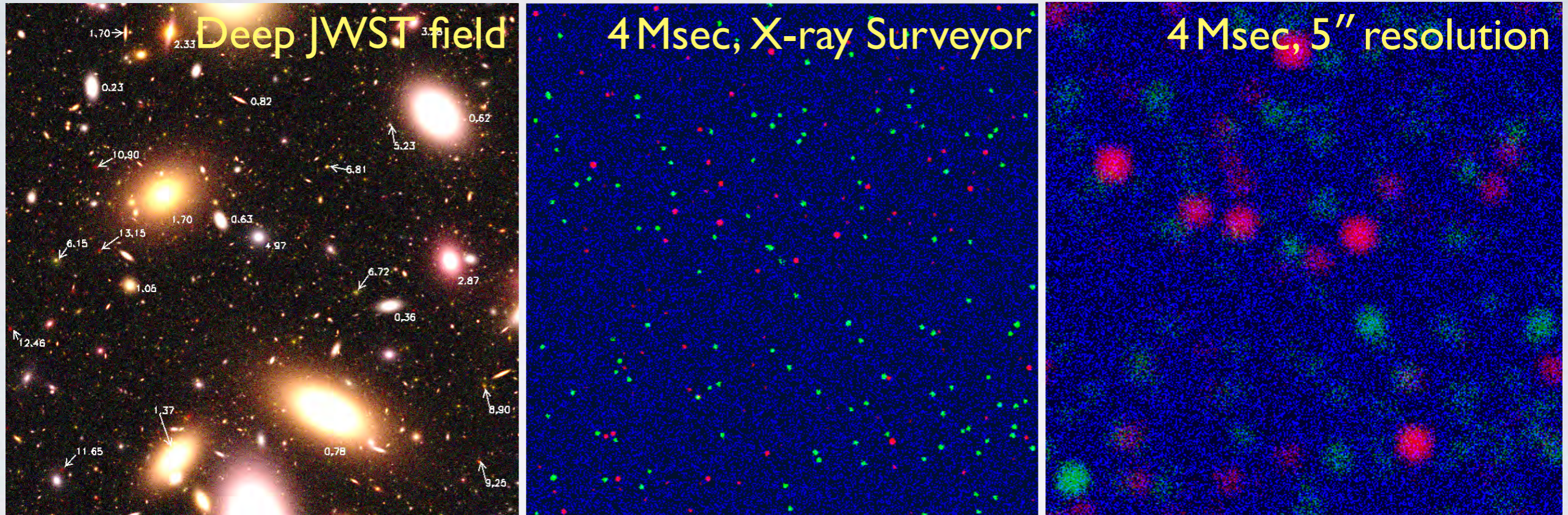

- JWST will detect  $\sim 2 \times 10^6$  gal/deg<sup>2</sup> at its sensitivity limit (Windhorst et al.). This corresponds to 0.03 galaxies per 0.5'' X-ray Surveyor beam (not confused), and 3 galaxies per ATHENA 5'' beam (confused).
- X-ray confusion limit for ATHENA is  $2.5 \times 10^{-17}$  erg/s/cm<sup>2</sup> (5× worse than the current depth of *Chandra* Deep Field). This corresponds to  $M_{\text{BH}} \sim 3 \times 10^6 M_{\text{Sun}}$  at  $z=10$  — above seed mass range. Confusion in OIR id's further increases the limit ( $M_{\text{BH}} \sim 10^7 M_{\text{Sun}}$  at  $z=8$  is quoted by ATHENA team).
- X-ray Surveyor will reach  $1 \times 10^{-19}$  erg/s/cm<sup>2</sup>. This corresponds to  $M_{\text{BH}} \sim 10,000 M_{\text{Sun}}$  at  $z=10$  — well within the plausible seed mass range. *Each X-ray Surveyor source will be associated with a unique JWST-detected galaxy.*

# *Galaxy formation: solving the nature of feedback problem*

$T < 10,000$  K : Optical & IR light + radio

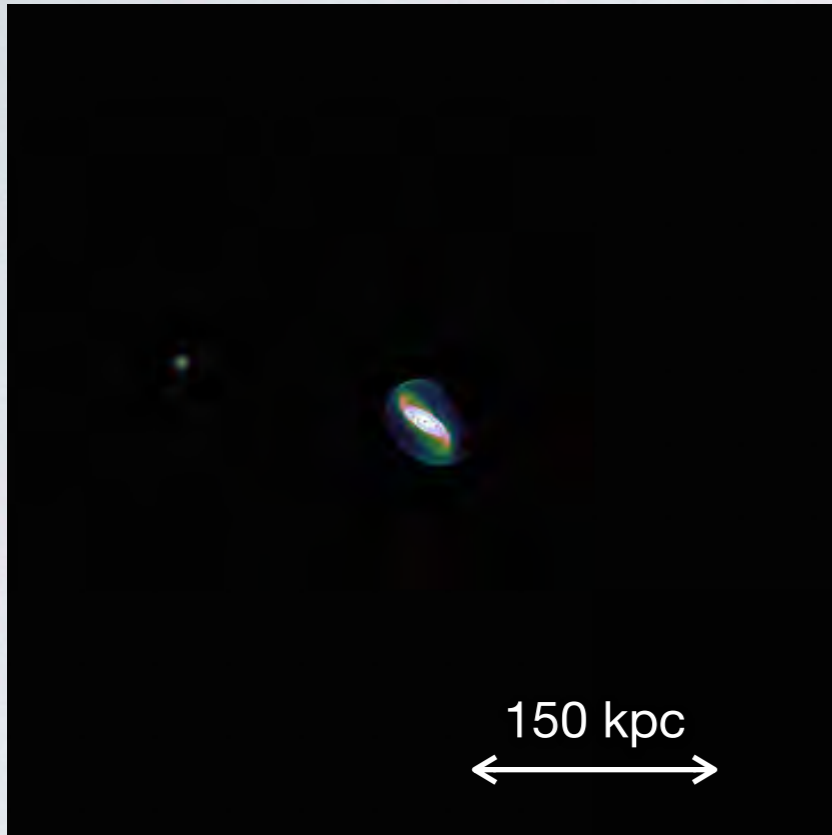

$T > 1,000,000$  K : X-rays

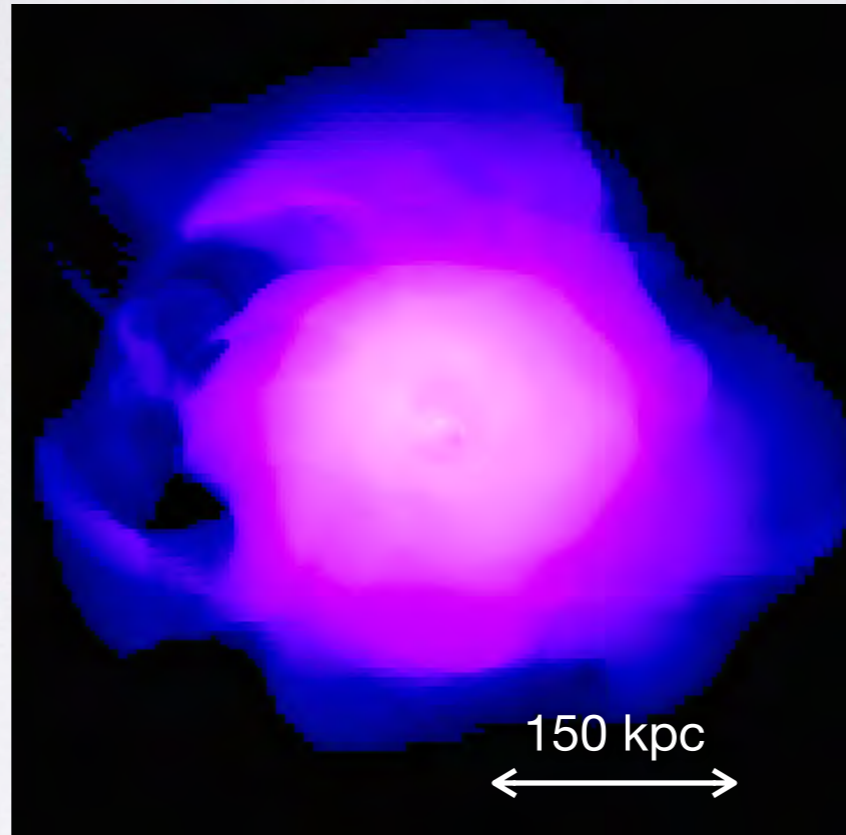

$T \sim 100,000$  K : OVI absorption in UV

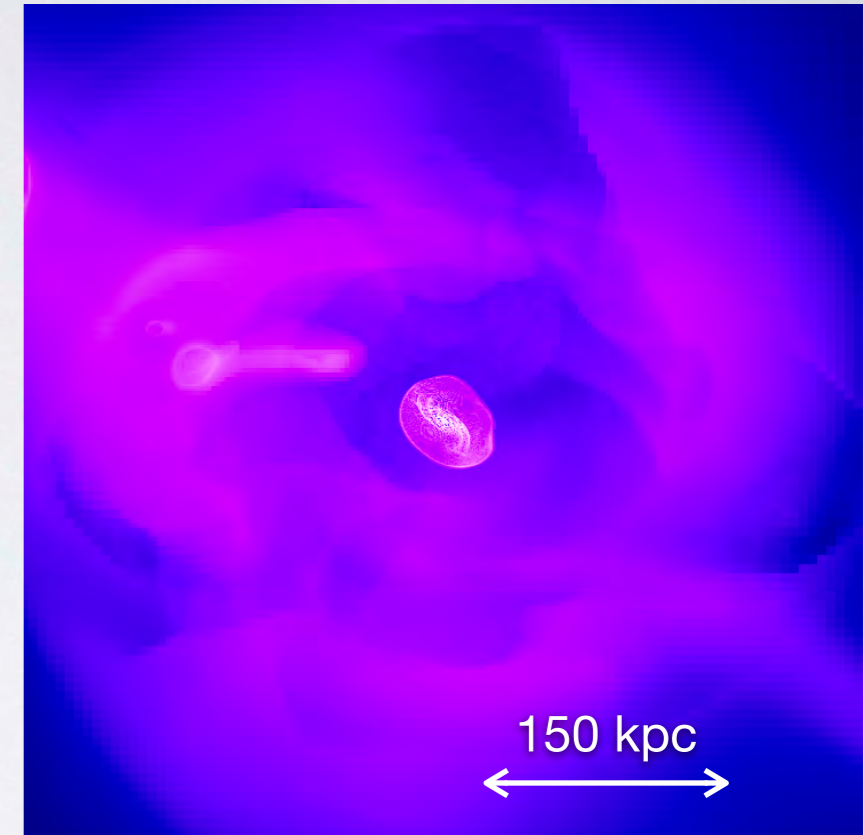

Simulated 500 kpc light years region around Milky Way type galaxy in different wavebands.

~ 40% of baryons are converted to stars

~ 30% are observable in UV absorption

~ 30% are heated to X-ray temperatures — unique signature of energy feedback

**Goals:** detect and characterize hot halos around Milky Way-size galaxies to  $z \sim 1$ , hot gas in group-sized objects at  $z = 6$ , including those around SDSS quasars; map in detail galaxy winds at  $z \sim 0.01$ .

**Required capability:** sensitivity & ability to separate diffuse emission from central sources



# Structure of the Cosmic Web

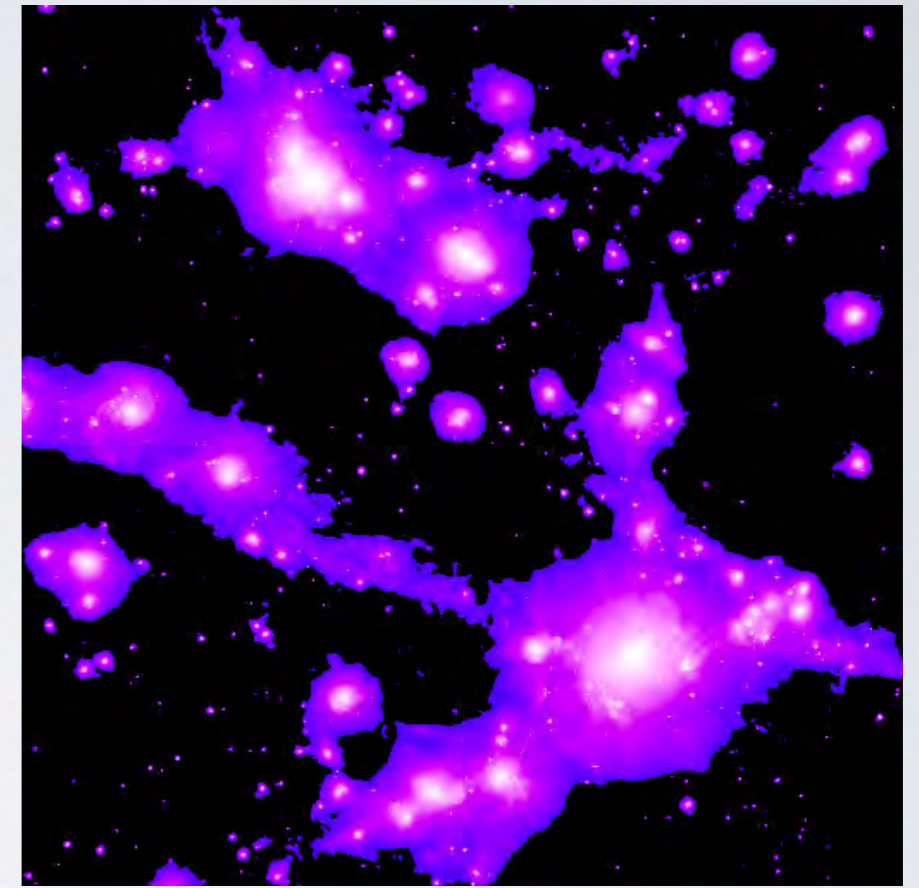
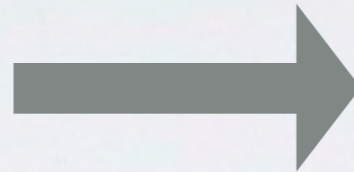
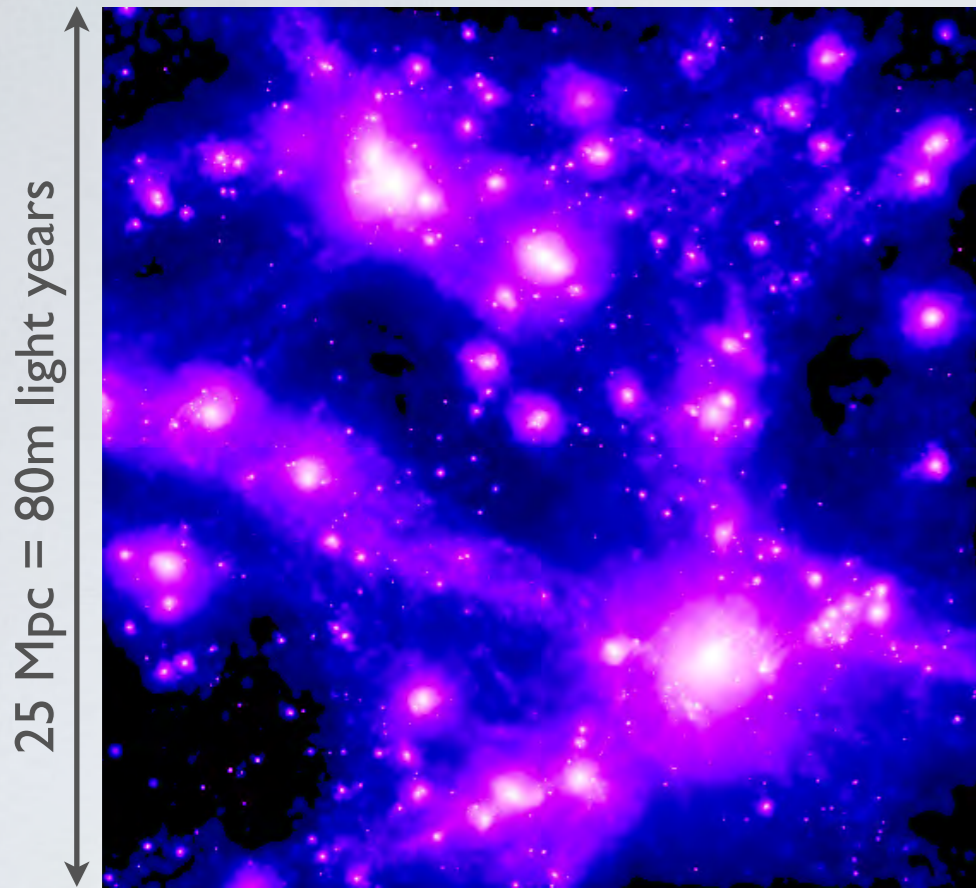

Simulated X-ray surface brightness (0.5–2 keV) in a 25 Mpc box around a massive ( $\sim 10^{15} M_{\text{Sun}}$ ) galaxy cluster (Rasia, Dolag et al.)

Zones accessible to X-ray Surveyor observations in emission

- Diffuse ionized intergalactic gas contains most of baryons in the local Universe.
- A large fraction of these baryons is heated to X-ray temperatures,  $T > 10^6$ .
- Current absorption line observations in UV (OVI) and X-rays (OVII) only probe a small fraction of volume and phase space.
- For full understanding of the intergalactic gas, need ability *to map* Hydrogen + Helium.

Regions with  $\rho/\rho_{\text{mean}}$  above  $\sim 30$  and  $T > 1.5 \times 10^6$  K (containing  $\sim 50\%$  of hot diffuse baryons by mass) will be observable with X-ray Surveyor *in emission*.

**Required capability:** resolve and remove cosmic X-ray background sources.

# Plasma Physics in astronomical objects

Chandra image of Perseus cluster: energy output from supermassive black hole balances radiative cooling.

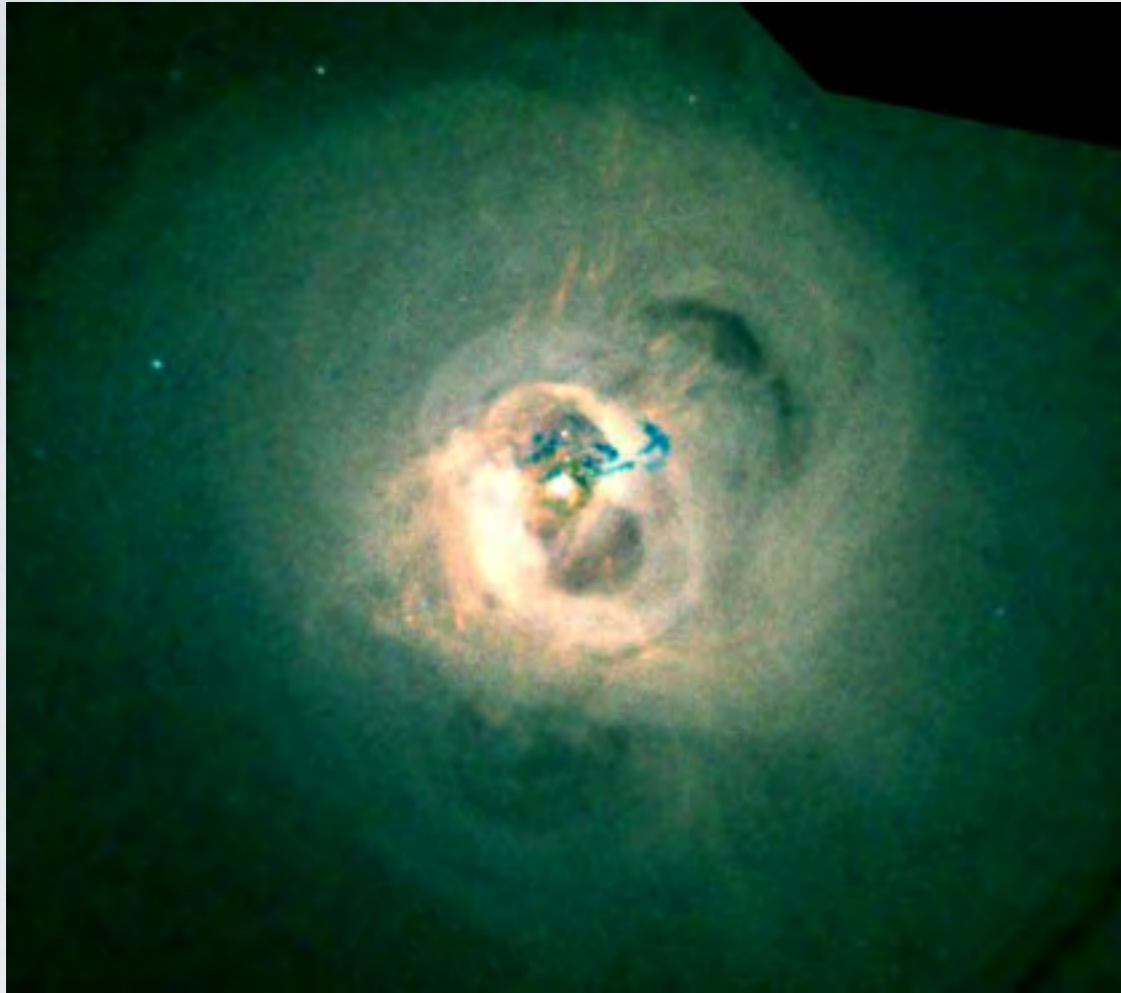

*Credit: J. Sanders*

Unsharp mask image.  
Ripple interfaces are  $< 1$  arcsec wide.

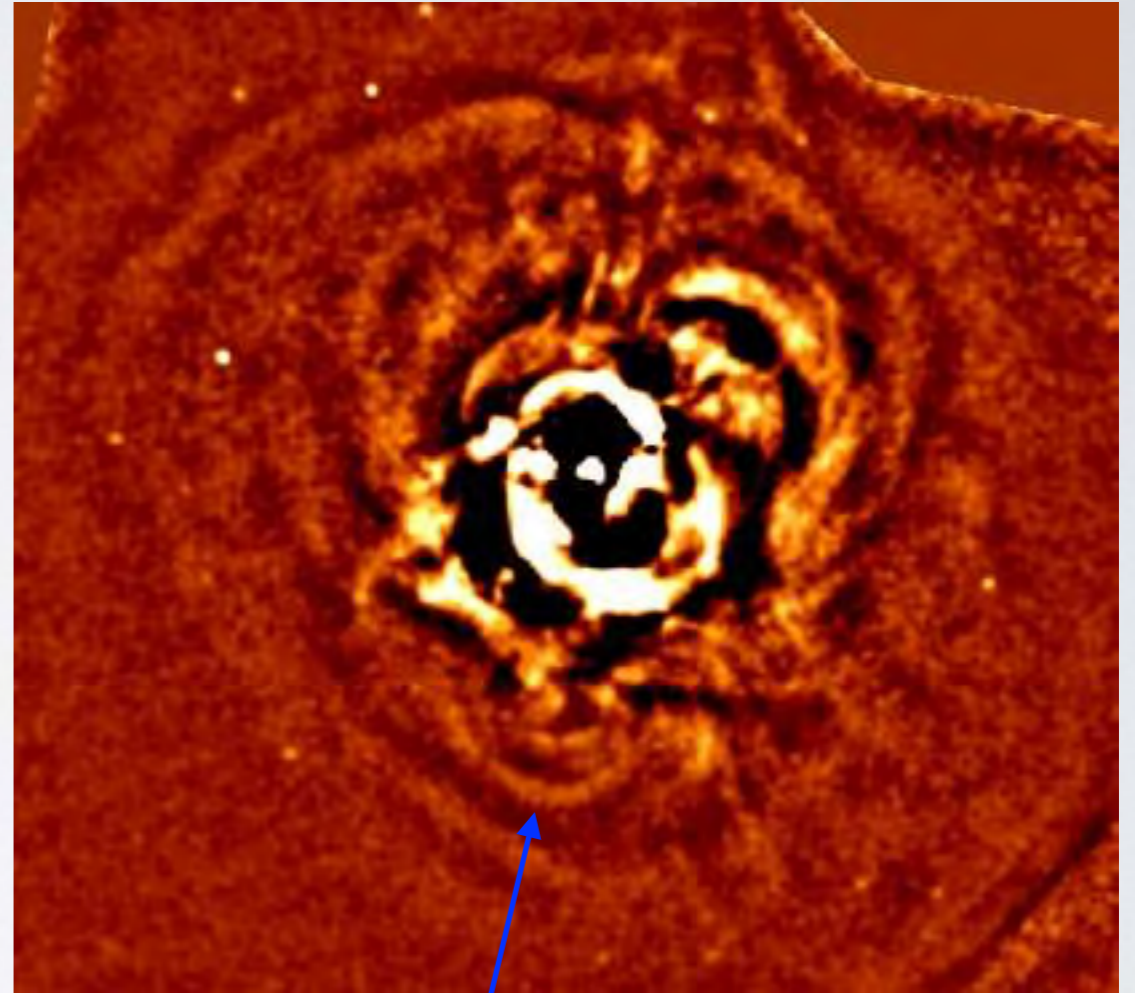

Sound waves in viscous plasma (Fabian et al. 2003),  
or turbulence in a stratified atmosphere (Zhuravleva,  
..., Fabian, ... et al. 2015)?

# Plasma Physics in astronomical objects

Chandra image of Perseus cluster: energy output from supermassive black hole balances radiative cooling.

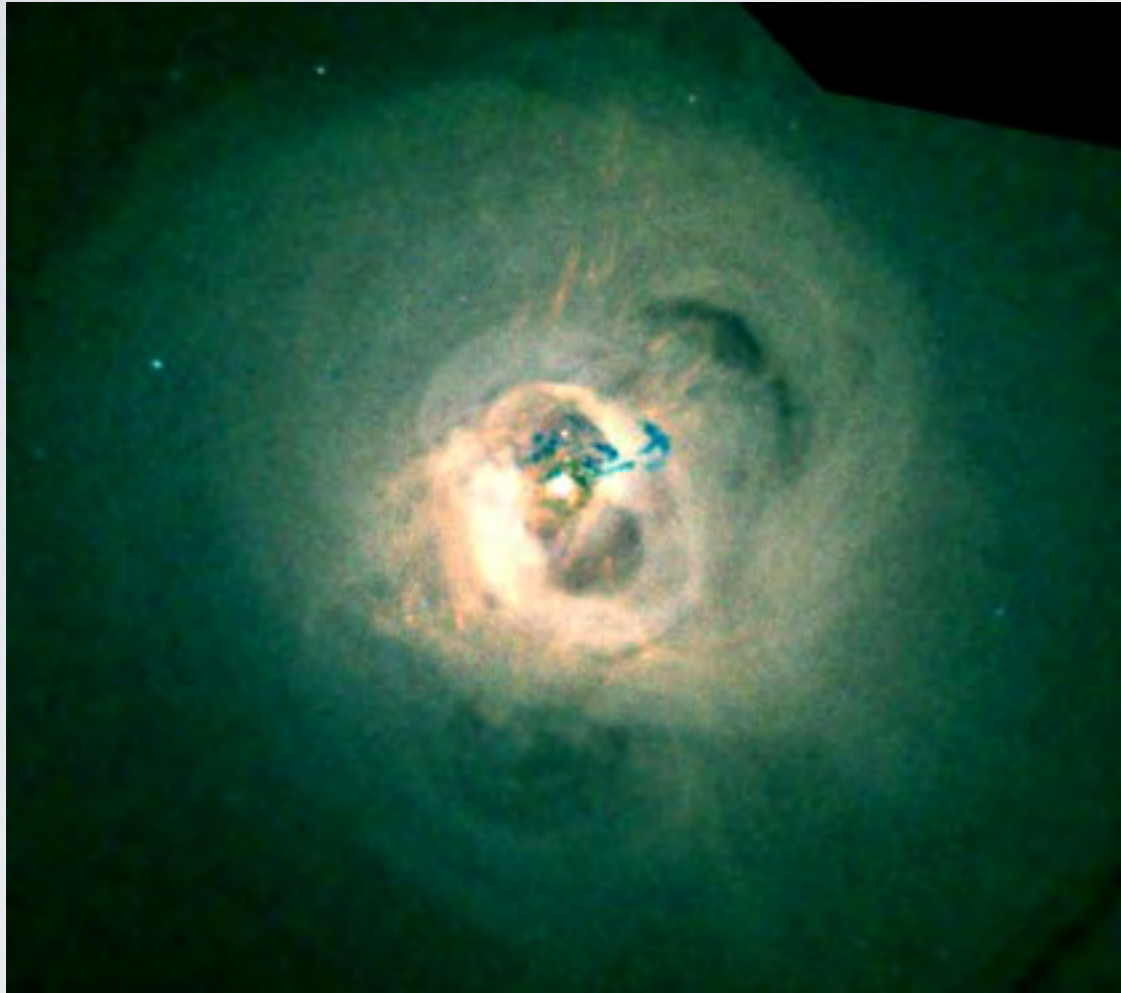

Credit: J. Sanders

Bulk motions with  $v=30\text{km/s}$  and  $100\text{ km/s}$  Doppler line widths can be measured with microcalorimeter (compare with  $c_s\sim 1000\text{ km/s}$ ).

X-ray Surveyor: detailed 3D tomography.

ATHENA: overall Doppler line widths.

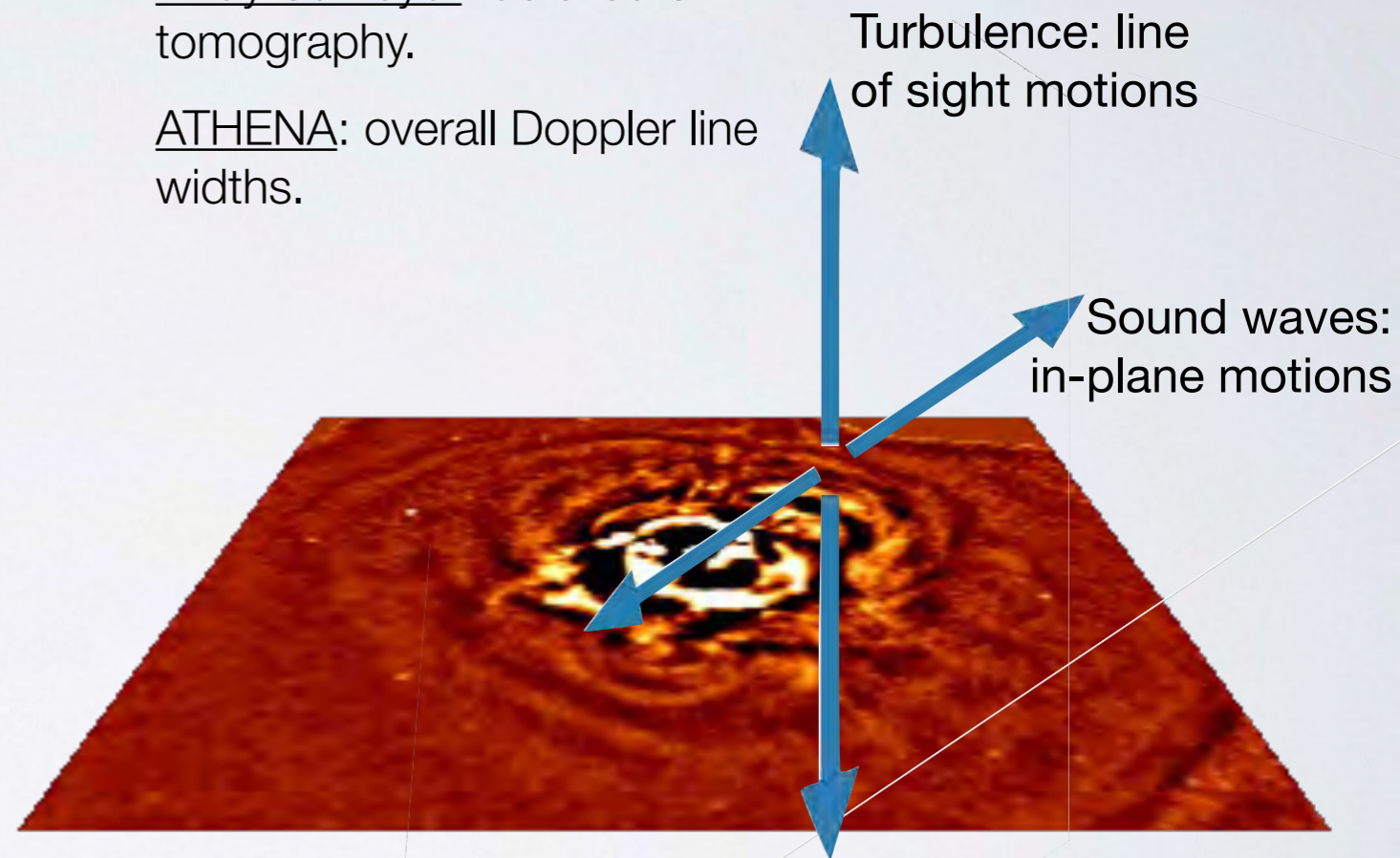

**Required capability:** spatially resolved spectroscopy on dissipation scales (close to  $\sim 1''$  based on *Chandra* images)

# *Plasma physics, gas dynamics, relativistic flows in astronomical objects*

Spatially resolved spectroscopy also critical for:

- Detailed structure of supernova remnants
- Particle acceleration in pulsar wind nebulae
- Jet-IGM interactions
- Studies of plasma flows in the Solar system, stellar winds & ISM via charge exchange emission

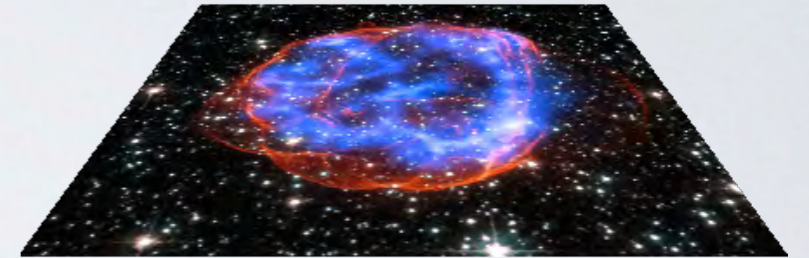

# High throughput, high resolution spectroscopy

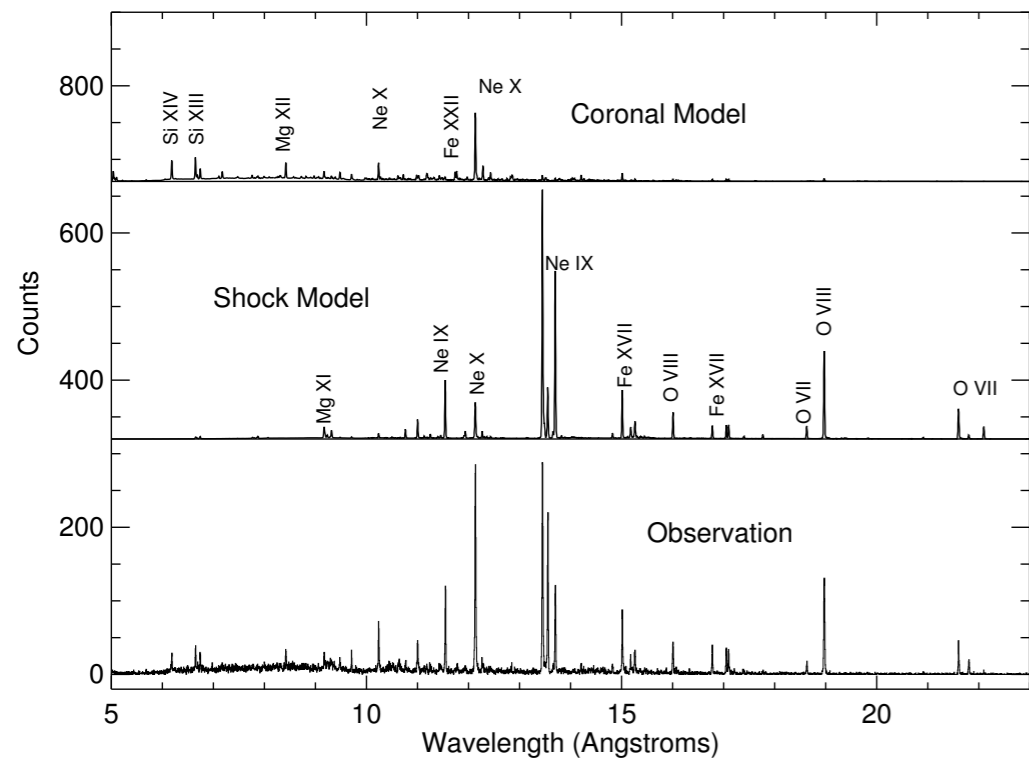
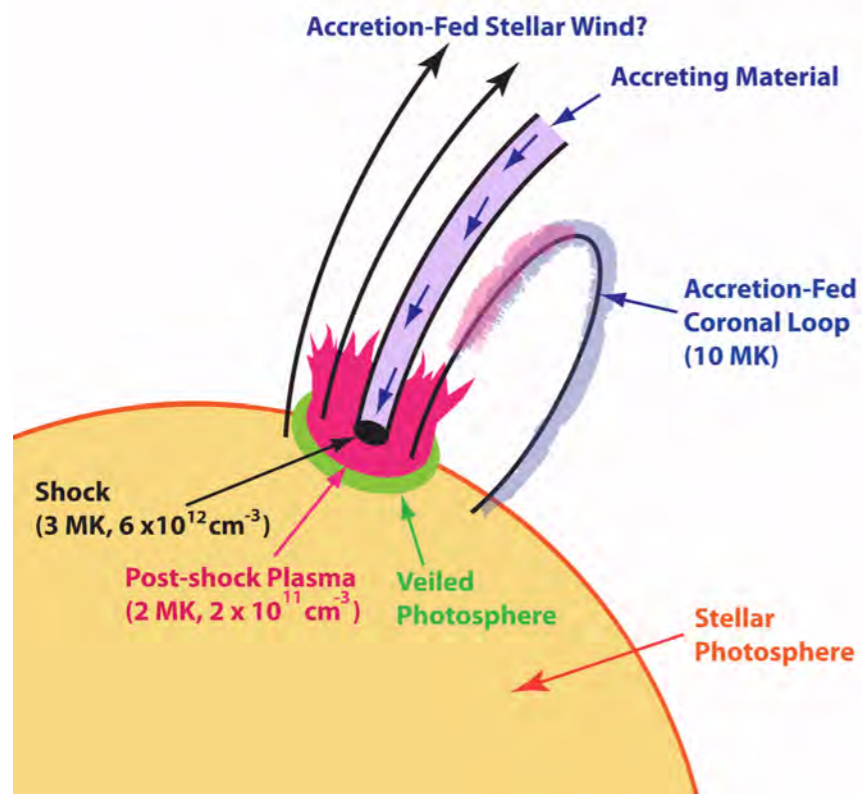

X-ray Surveyor will improve resolving power by  $\times 5-10$ , and throughput for grating spectroscopy by  $>2$  orders of magnitude. Expect revolution in studies of

- Coronal activity in young stars
- Star-planet interactions (e.g. close-in Hot Jupiter systems)
- Gas flows in the vicinity of the AGN central engine
- X-ray absorption line detections (Cosmic Web, galactic halos)

# Athena

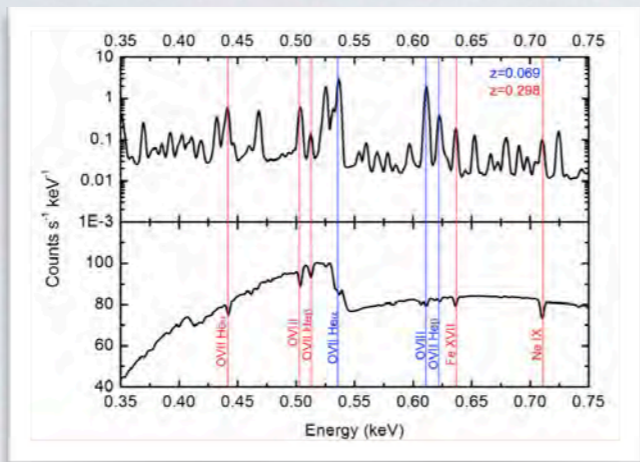
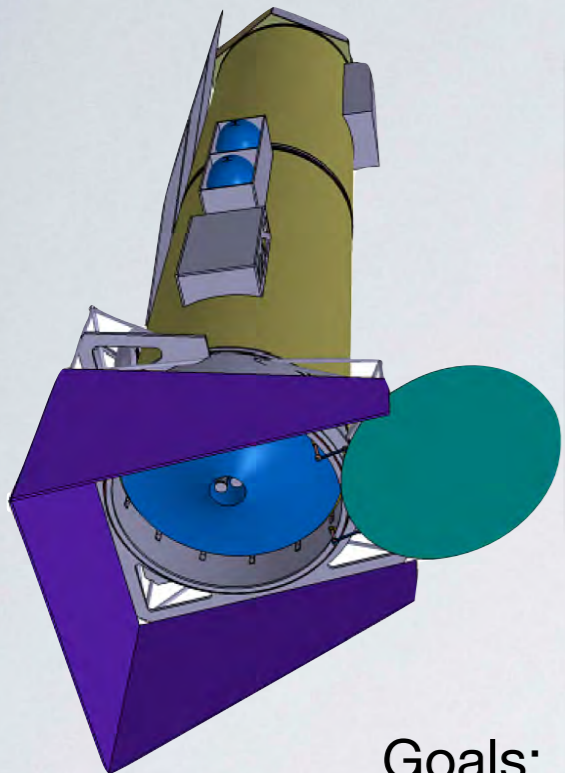

Goals:

- Microcalorimeter spectroscopy ( $R \approx 1000$ )
- Wide, medium-sensitivity surveys

Area is built up at the expense of coarser angular resolution ( $10\times$ ) & sensitivity ( $5\times$ )

# X-ray Surveyor

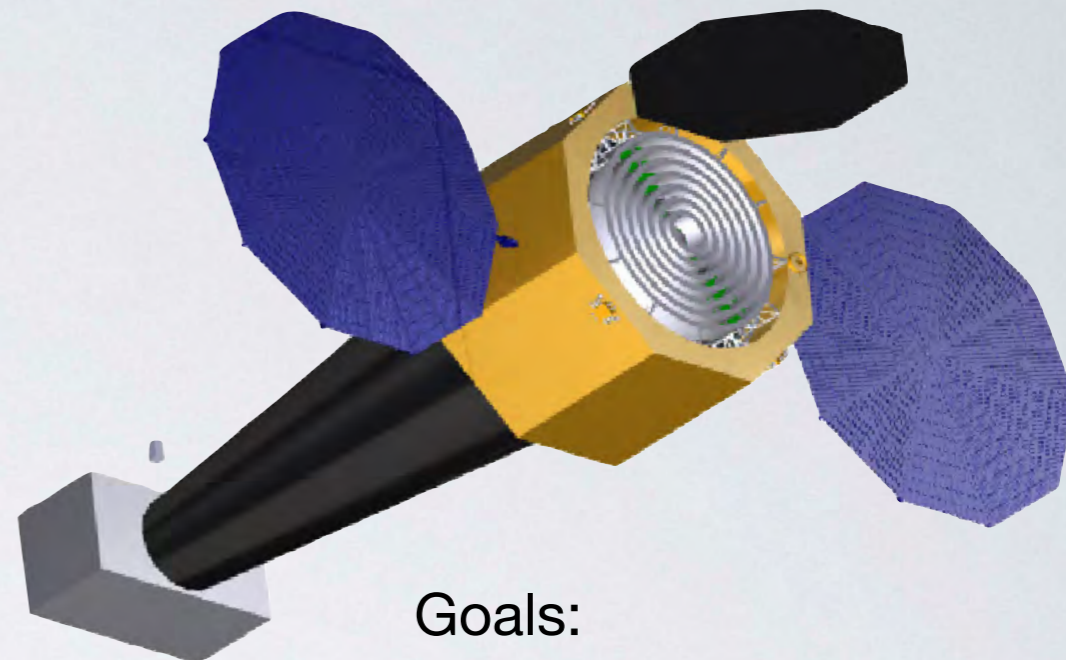

Goals:

- $50\times$  sensitivity
- $R \approx 1000$  spectroscopy on  $1''$  scales adds 3rd dimension to the data
- $R \approx 5000$  spectroscopy for point sources

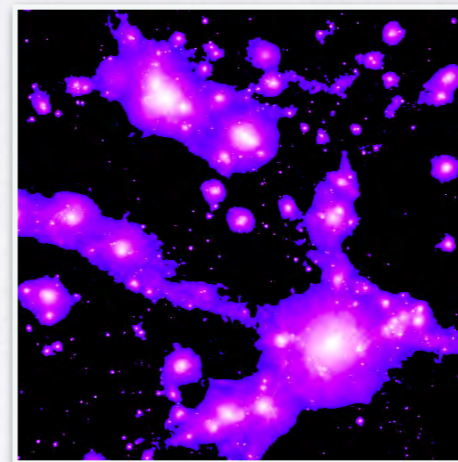

- ✓ Area is built up while preserving *Chandra* angular resolution ( $0.5''$ )
- ✓  $10\times$  field of view with fine imaging

# Chandra

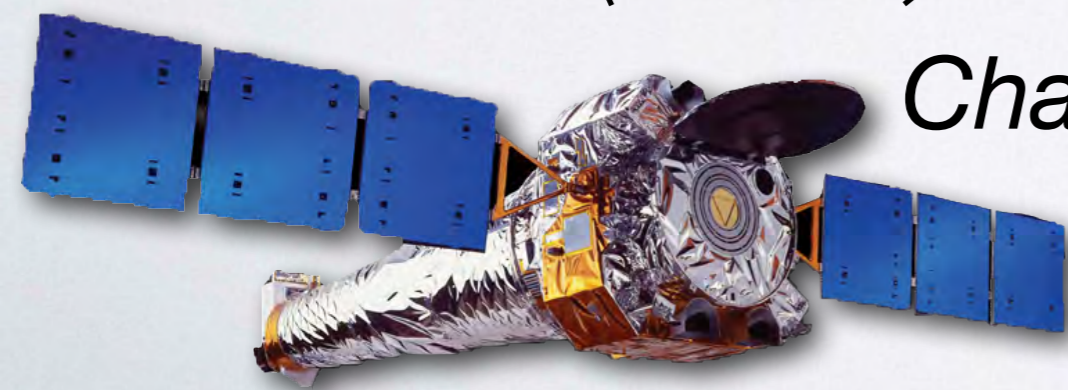

# *X-ray Surveyor strawman mission concept*

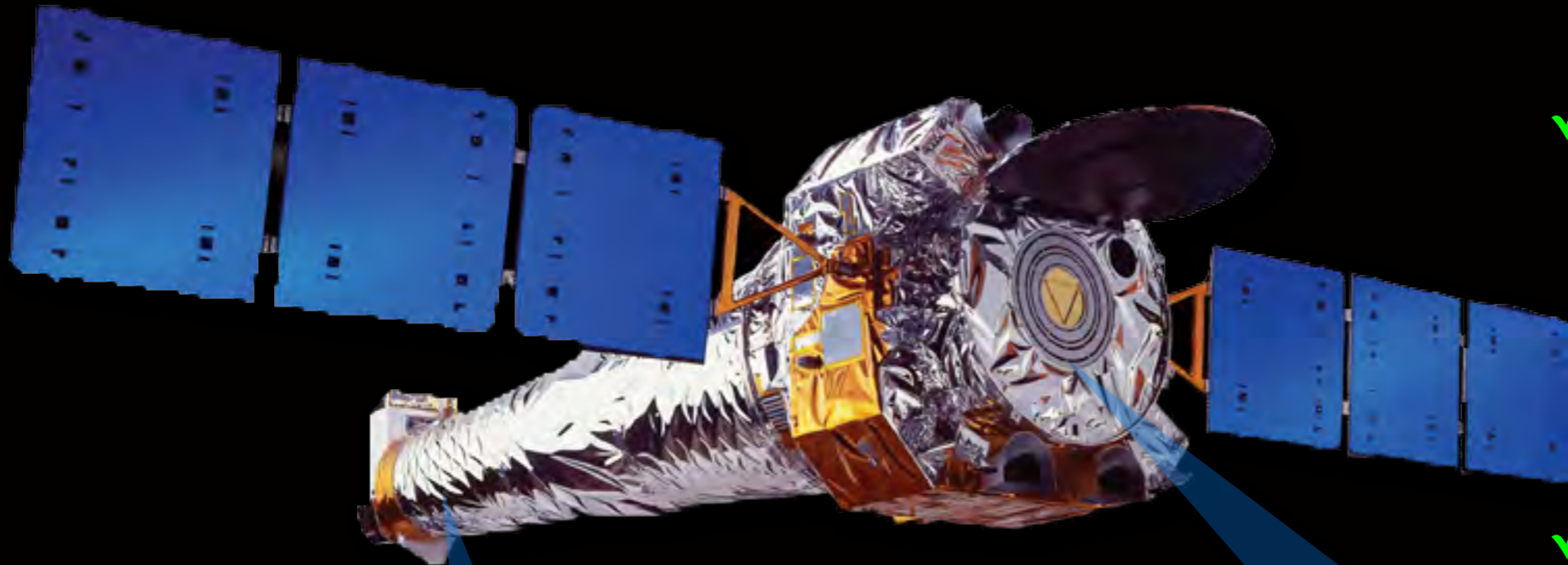

✓ Technology incorporates *Chandra* heritage and IXO development

✓ Most spacecraft requirements similar to those achieved for *Chandra*, with some required extensions (power, data rate) being straightforward

✓ *Chandra*-like cost

## *Next-generation science instruments, e.g.:*

- 5'×5' microcalorimeter with 1'' pixels and high spectral resolution, 0.2–10 keV
- 22'×22' CMOS imager with 0.33'' pixels, 0.2–8 keV
- insertable gratings,  $R = 5000$ , 0.2–1.2 keV

Next-generation mirrors. Lower mass, same angular resolution, same focal length as *Chandra*'s. A factor of 30 (50 with QE gains) more effective area. Sub-arcsec imaging over 15×15' field.

# ***X-ray Surveyor strawman mission concept***

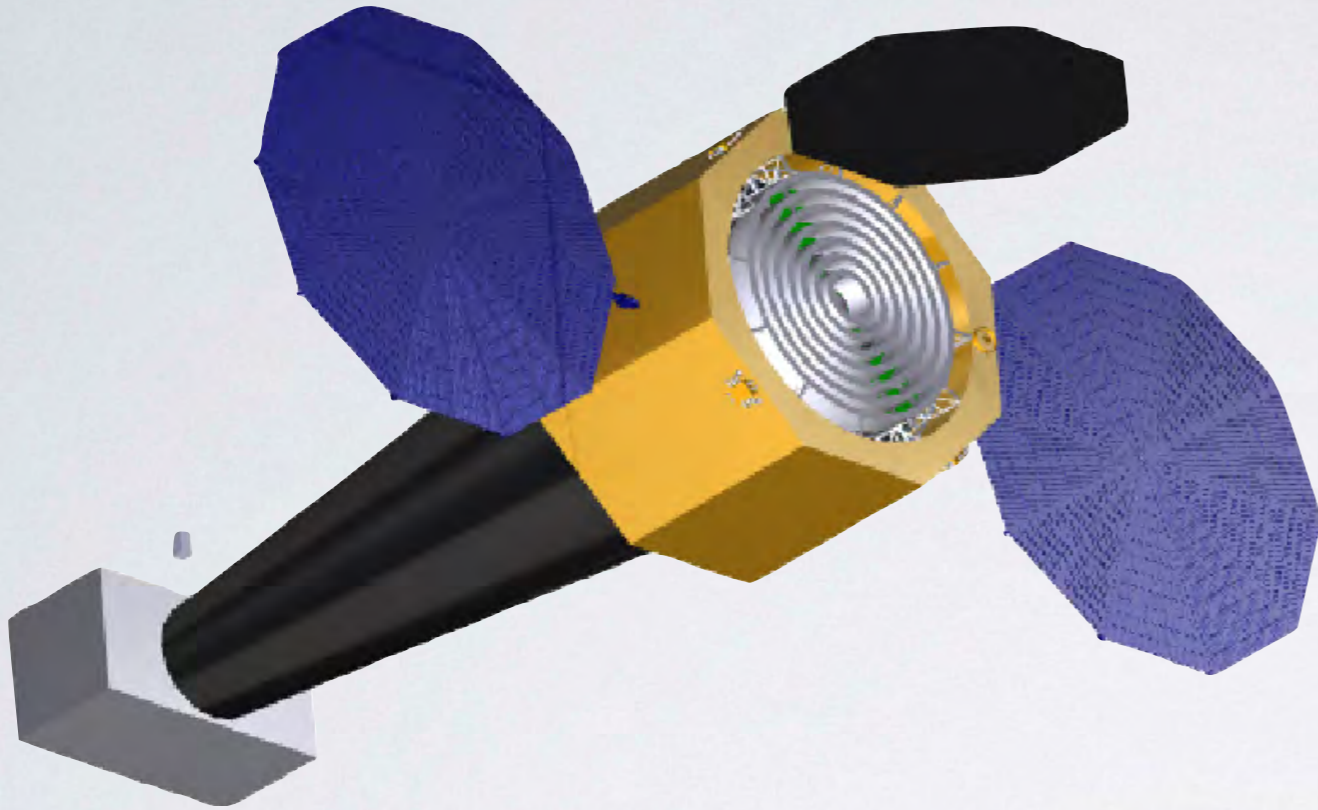

*Mission concept for X-ray surveyor developed by the MSFC Advanced Concepts Office & informal mission concept team: M. Weisskopf, J. Gaskin, B. Ramsey, Steve O'Dell (MSFC), A. Vikhlinin, H. Tananbaum, P. Reid, D. Schwartz, R. Kraft (SAO), D. Burrows, A. Falcone, L. Townsley (PSU), M. Bautz, R. Heilmann (MIT), S. Bandler, A. Ptak, R. Petre, C. Kilbourne (GSFC), R. McEntaffer (Iowa), F. Harrison (Caltech), A. Kravtsov (Chicago), P. Natarajan (Yale), S. Heinz (Wisconsin), C. Kouveliotou (GWU)*

*Looked at Structures, Thermal control, Mechanisms, Propulsion, Guidance, navigation & control, Avionics, Power, Orbit trade & launch vehicle, Radiation environments, Initial cost estimates.*

Detailed report at the June 2015 HEAD meeting in Chicago. Preliminary highlights:

- Indeed, a *Chandra*-like mission
- No system-level show stoppers
- Can be launched to L2 with Atlas V-551
- Cost roughly \$2.5B–\$3B with lots of refinements still in progress



# Technologies for next-generation X-ray mirror

New mirror can be built from densely packed thin segments, mounted into modules.  
~1200 kg for 2.3m<sup>2</sup> of collecting area

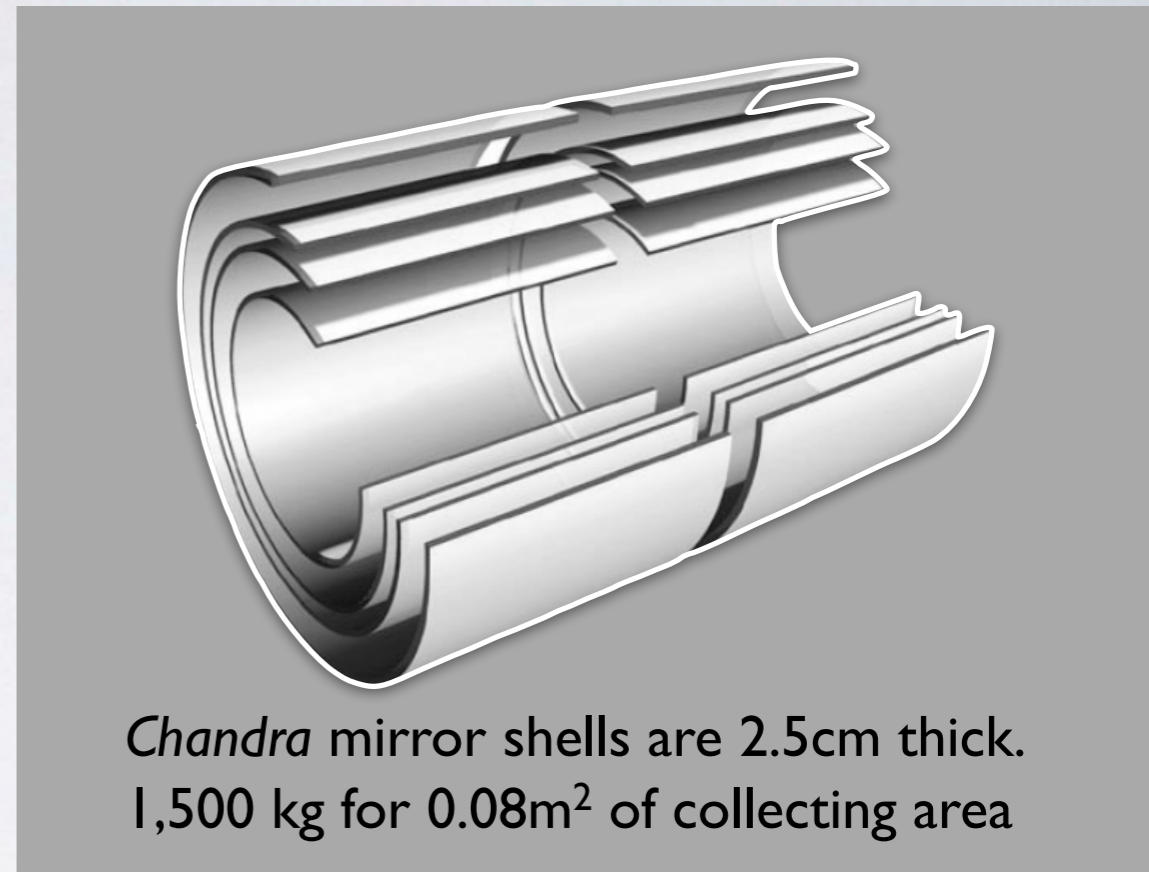
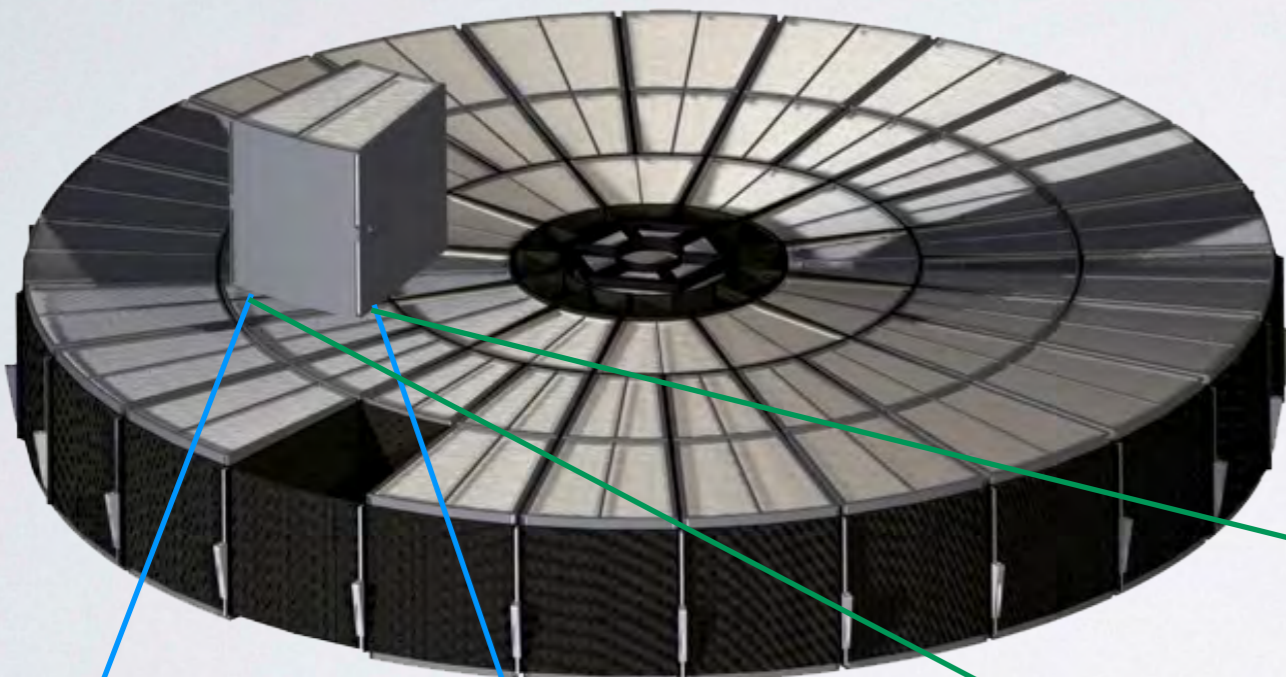

Chandra mirror shells are 2.5cm thick.  
1,500 kg for 0.08m<sup>2</sup> of collecting area

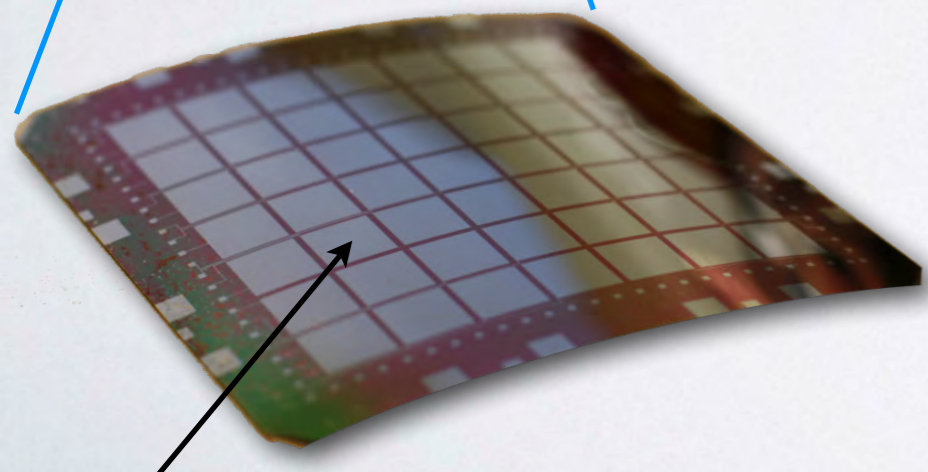

Make optics adjustable: piezo cells + integrated electronics  
+ strain gauges for in-flight feedback and control

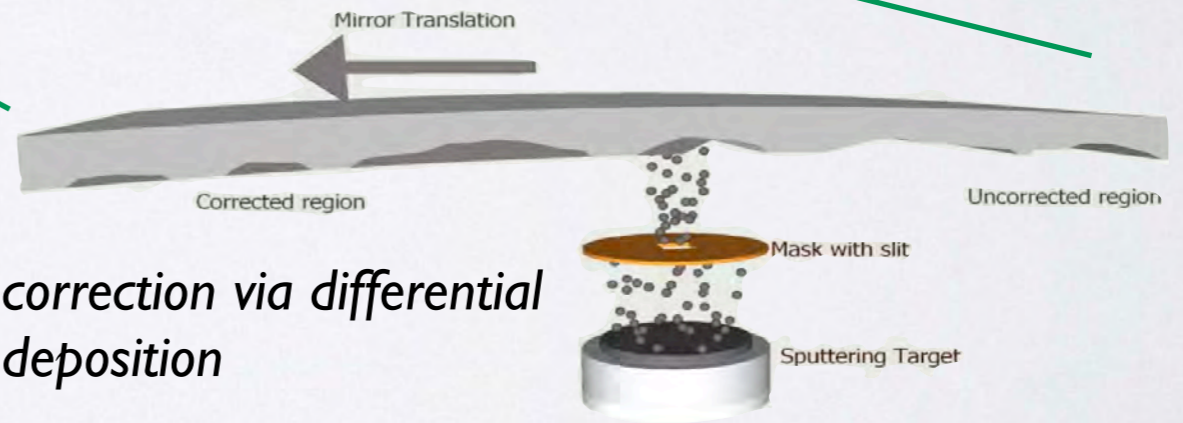

correction via differential  
deposition

or / and

several other techniques under study

# Technologies for notional instruments

**Microcalorimeter:** High spectral resolution for small pixels has been demonstrated in the lab. Challenge: Develop multiplexing approaches for building  $10^5$  pixel arrays.

*Much of future development is similar to ATHENA needs.*

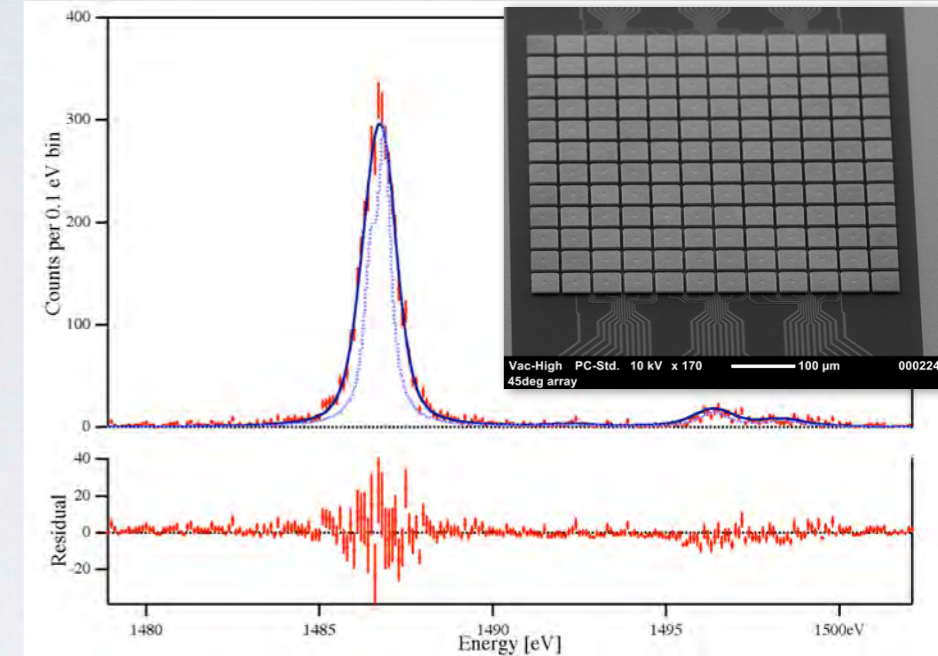

**Active pixel Si detectors:** Many required components (small pixels, high QE, low noise & dark current, radiation hardness, fast readout) have been demonstrated individually.

Challenges: Develop sensor package meeting all requirements, extend to a large-format camera, possibly approximate optimal focal surface for the mirrors.

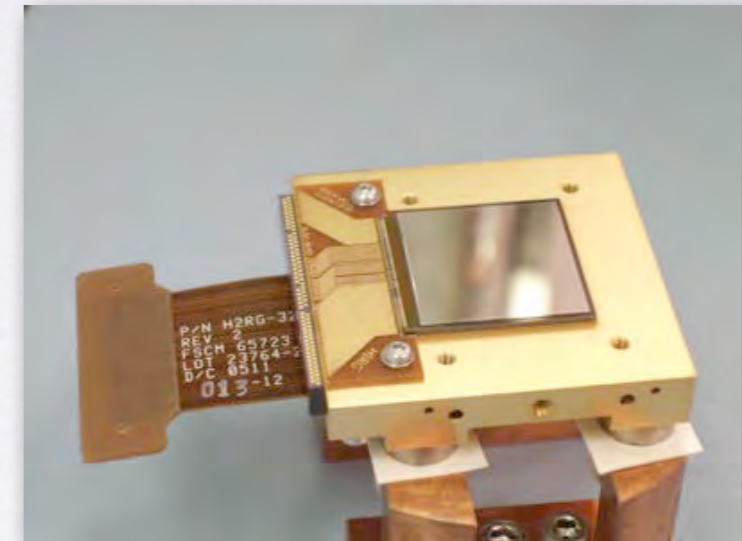

**Gratings:** Basic technology for both critical-angle transmission gratings and off-plane reflecting gratings is lab-proven. Challenges: continue improving production yield, develop techniques for robotic assembly.

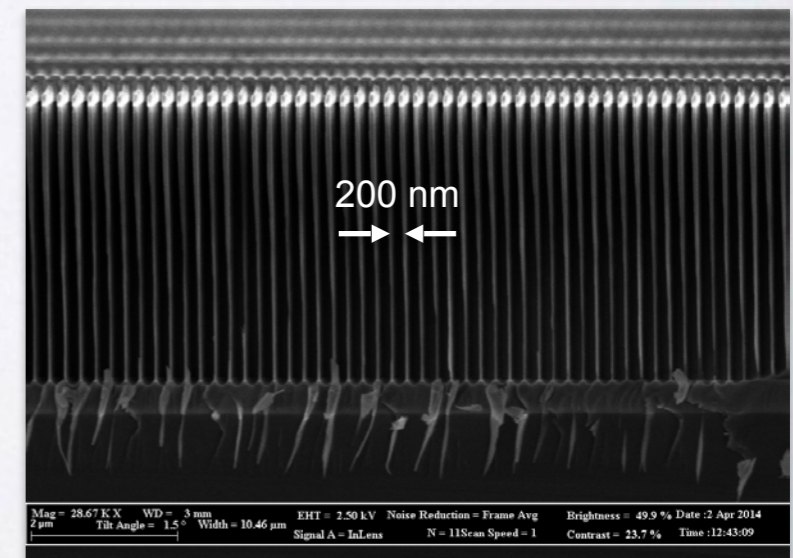

# *X-ray Surveyor*

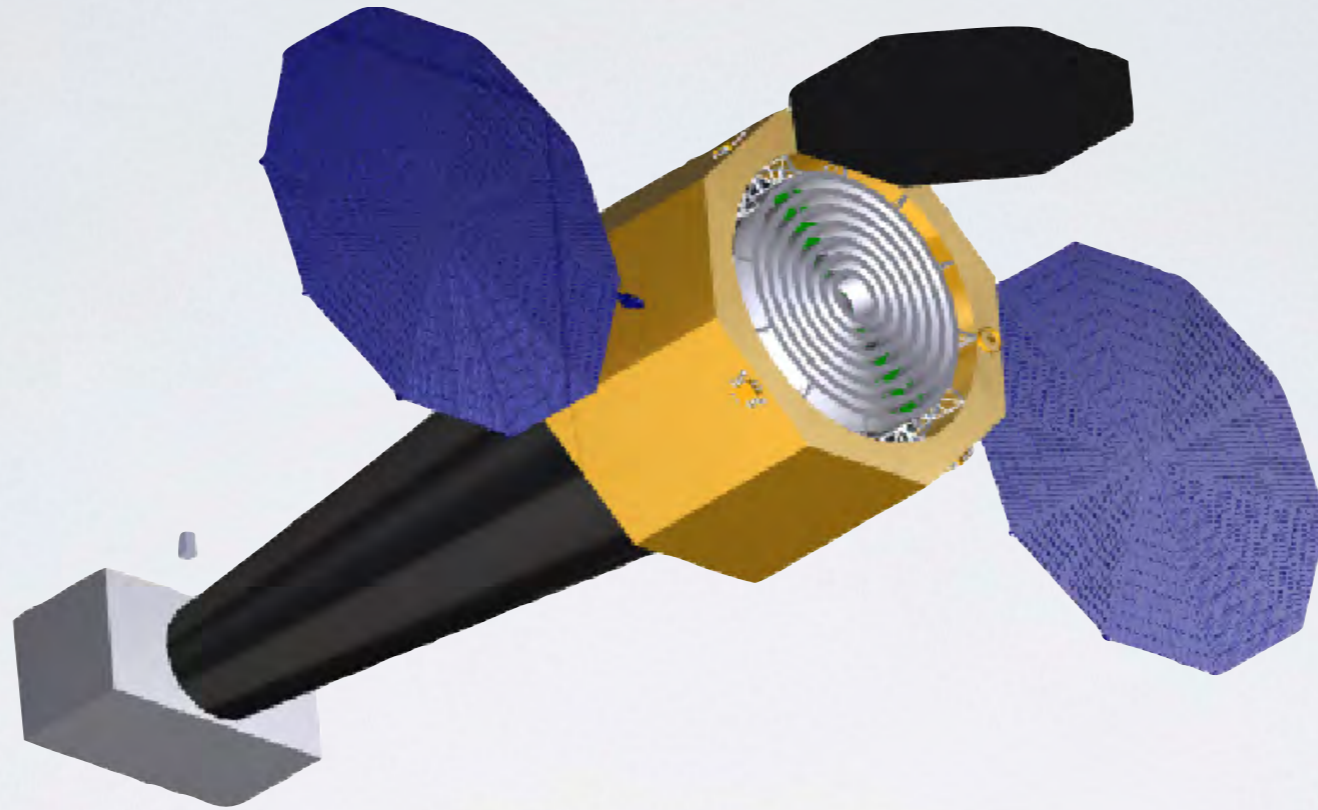

- **Capable**— 1–2 orders of magnitude gains in capabilities across the board.
- **Scientifically compelling**— Frontier science in objects from Solar system to stars to first accretion light in the Universe, revolution in high-resolution spectroscopy, and in understanding of plasma physics in astronomical objects.
- **Feasible**— Chandra-like mission, promising pace of technology development.