

ATHENA

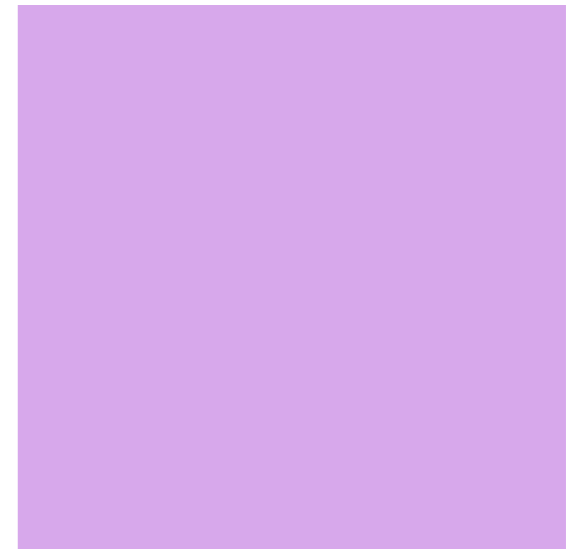

Athena Status  
and  
the X-ray Integral Field Unit

François Pajot and Didier Barret  
Institut de Recherche en Astrophysique et Planétologie

# The Hot Universe - key questions

- How do baryons in groups and clusters accrete and dynamically evolve in the dark matter haloes?
- What drives the chemical and thermodynamic evolution of the Universe largest structures?
- *What is the interplay of galaxy, supermassive black hole, and intergalactic gas evolution in groups and clusters?*
- *Where are the missing baryons at low redshift and what is their physical state?*

## Accretion in dark matter haloes

Map gas motions and turbulence to understand how baryons accrete and evolve in the largest dark matter potential wells of groups and clusters.

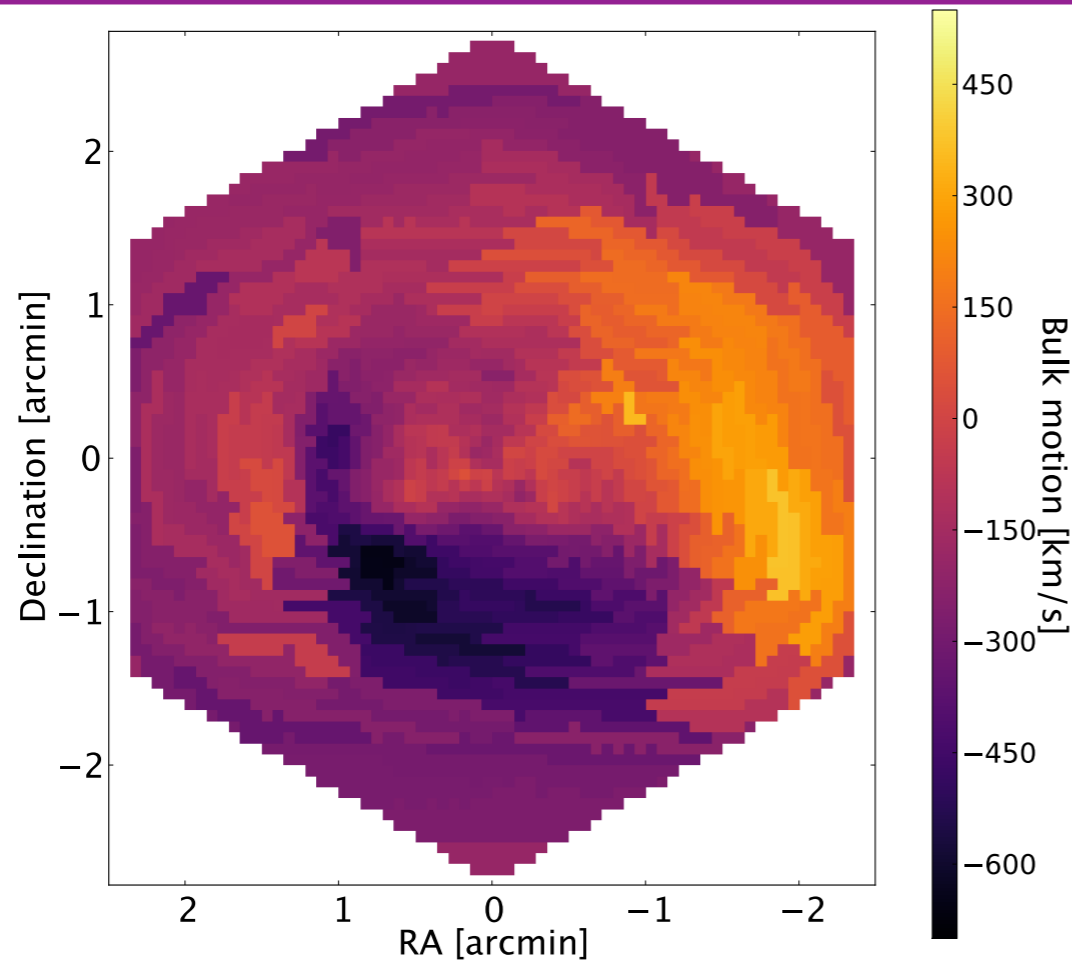

Simulated velocity maps (courtesy of Ph. Peille et al.). Ettori, Pratt et al. (2013) arXiv1306.2322

## Chemical enrichment

Synthesize the abundances using yields of various SN types and AGB stars to determine when the largest baryon reservoirs in galaxy clusters were chemically enriched

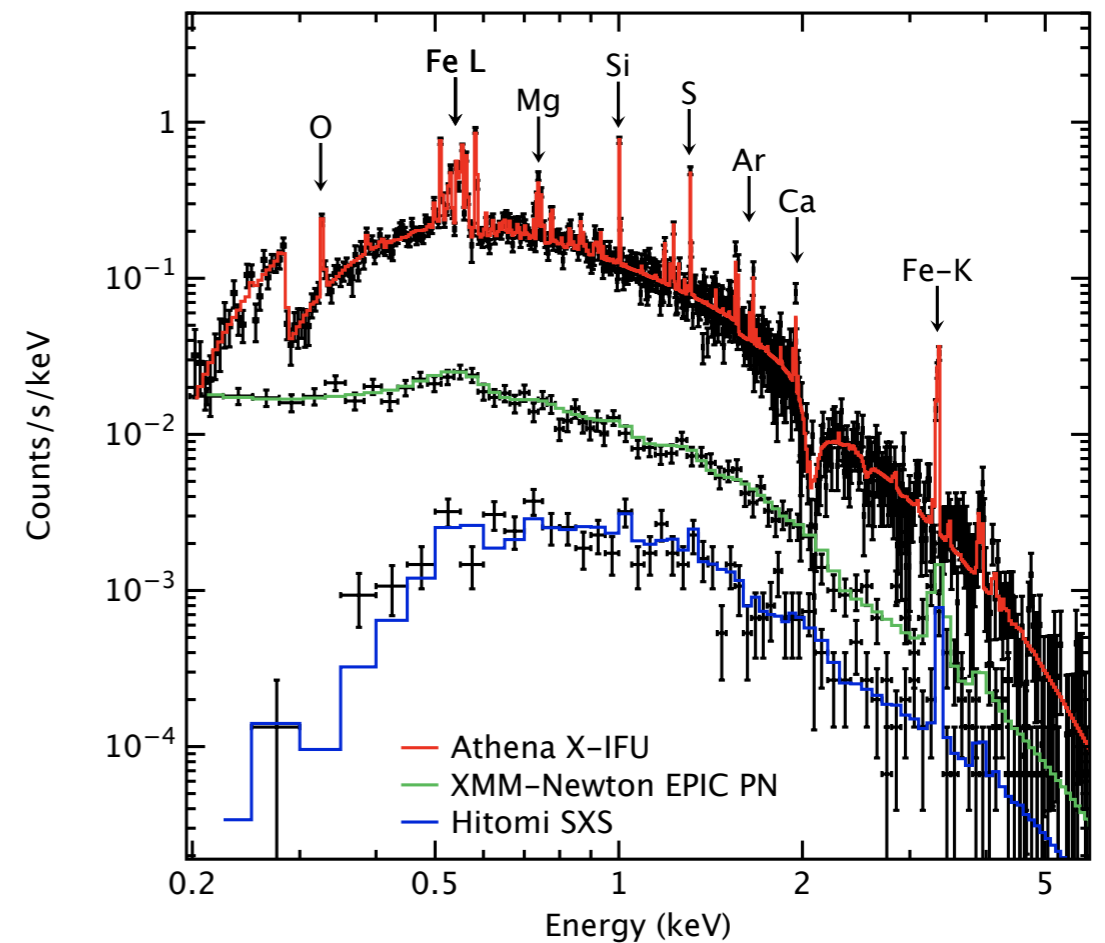

High resolution X-ray spectrum of a  $z=1$  cluster. Pointecouteau, Reiprich et al (2013), arXiv: 1306.2319

- *How do early supermassive black holes form, evolve and shape the Universe?*
- *What is the role of (obscured) black hole growth in the evolution of galaxies?*
- How do accretion-powered outflows affect larger scales via feedback?
- How do accretion and ejection processes operate in the near environment of black holes?

## AGN outflows

Characterize ejecta, by measuring ionization state, density, temperature, abundances, velocities and geometry of absorption and emission features of the winds and outflows and determine how much energy these carry.

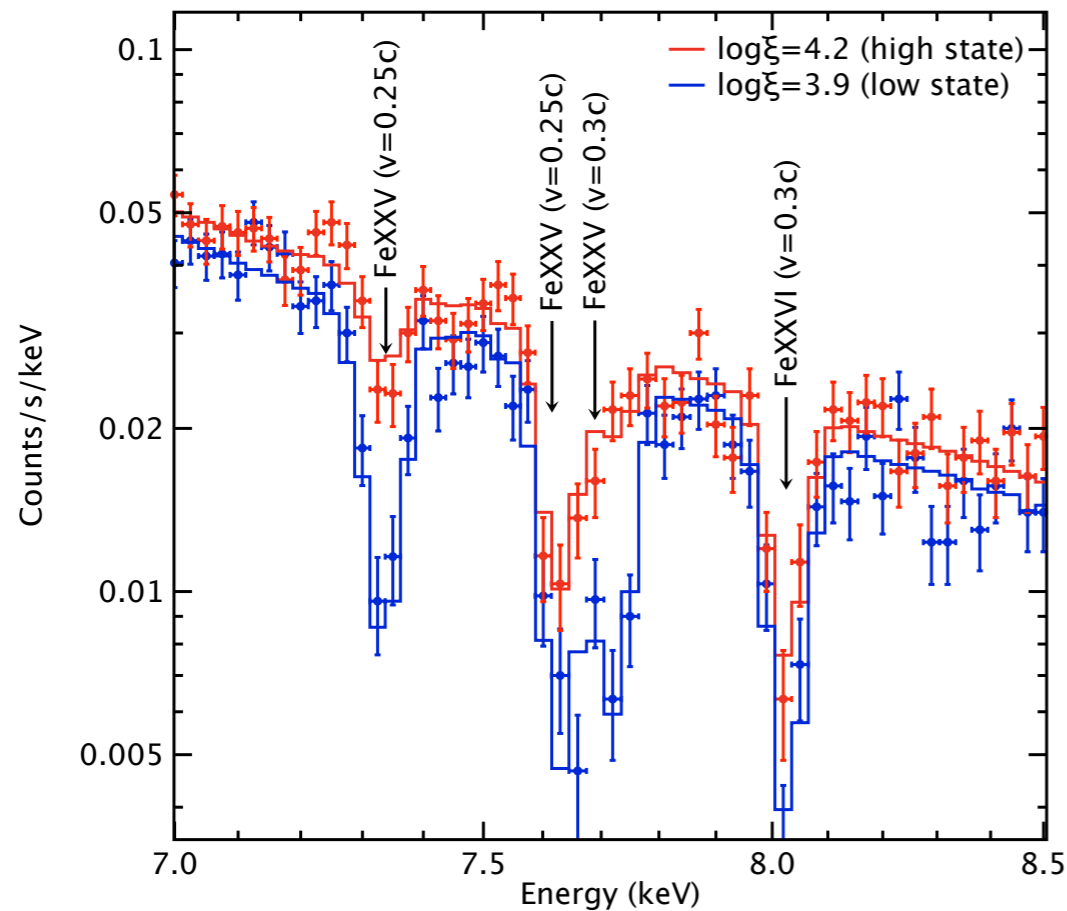

Simulated ultra-fast outflow spectrum - Cappi, Done et al 2013, arxiv: 1306.2330

## Black hole winds

Probe outflow properties and disk magnetic fields in galactic binaries and in the same systems determine the relationship between the accretion disk and its hot electron plasma. Understand the interplay of the disk/corona system with matter ejected in the form of winds and outflows.

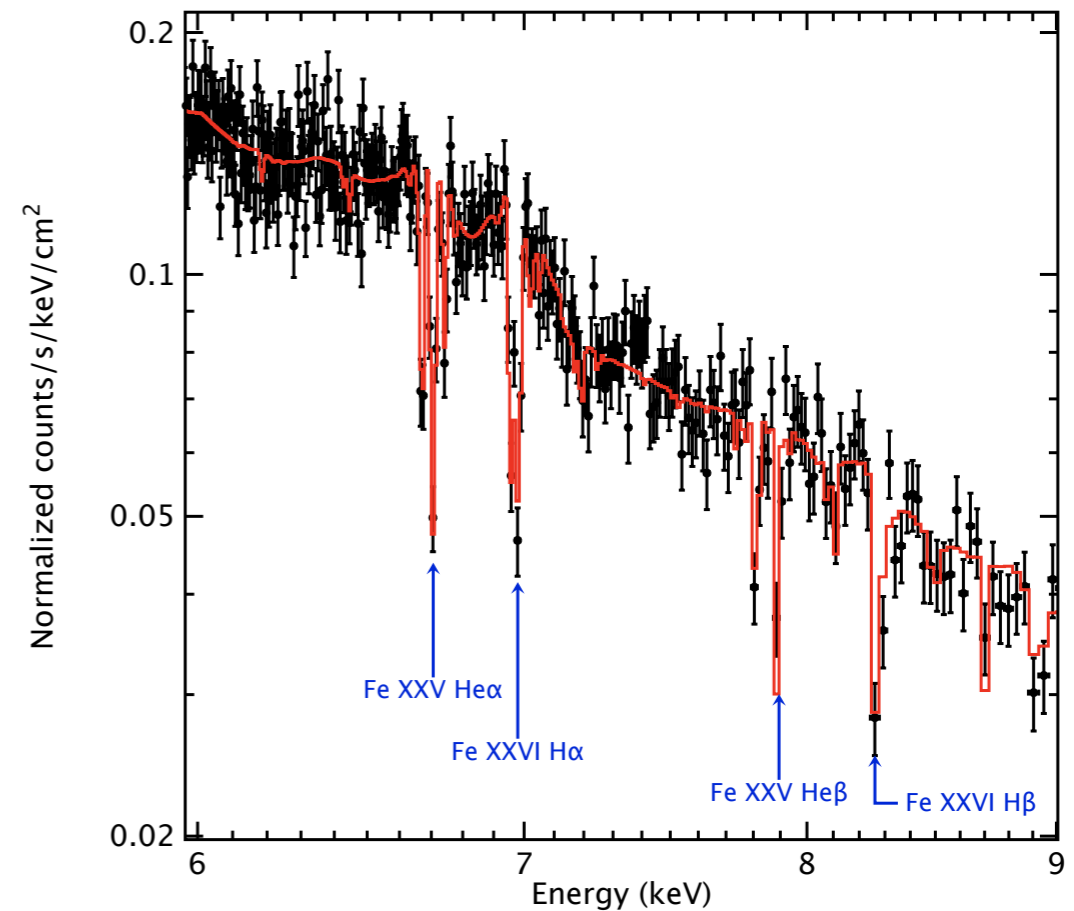

Disk wind spectrum of the stellar mass black hole GRS1915+105 - Barret et al. 2016 (courtesy J. Miller)

# Athena in a nutshell

- Second Large (L) mission of the ESA Cosmic Vision 2015-2035
- Launch year: end of 2028
  - with the newly developed Ariane 6 (64)
- A 7 ton spacecraft to be placed in a L2(L1) orbit
- Unprecedented collecting area in X-rays:
  - $2 \text{ m}^2$  at 1 keV and  $0.17 \text{ m}^2$  at 7 keV
  - 5'' angular resolution
- Two focal plane instruments with a movable mirror assembly
  - The Wide Field Imager (WFI) optimized for fine imaging and bright sources
  - The X-ray Integral Field Unit (X-IFU) optimized for high-resolution spectroscopy

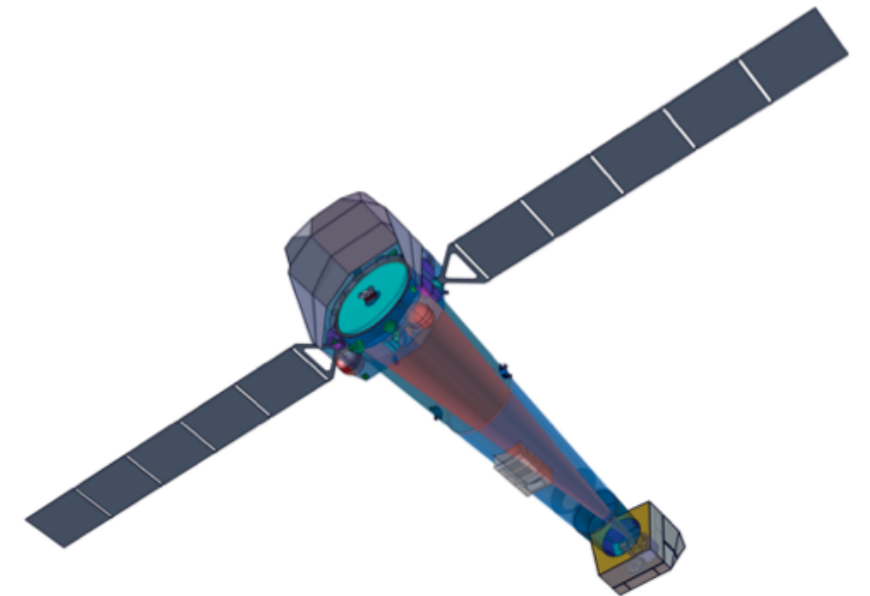

# Payload

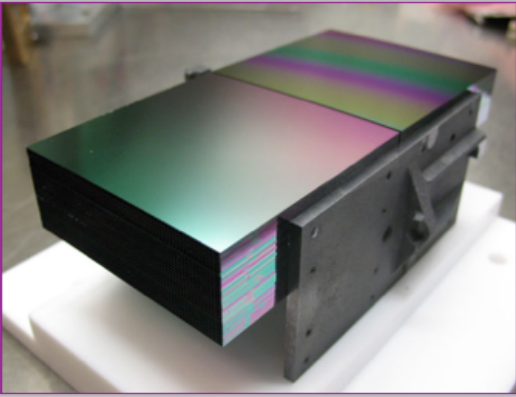
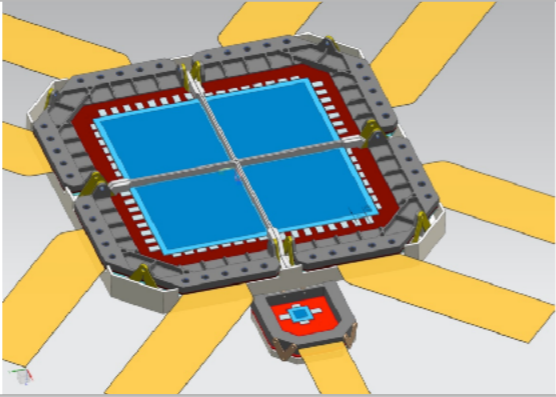
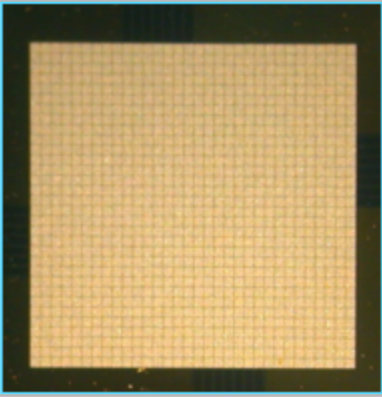
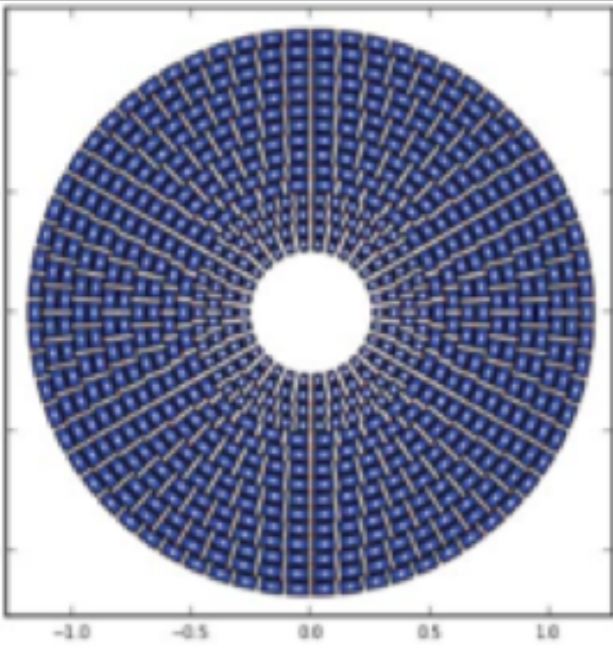
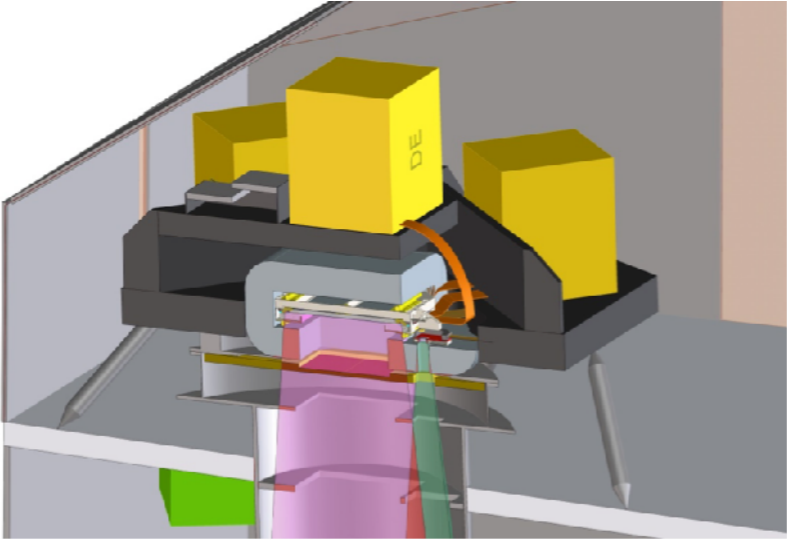
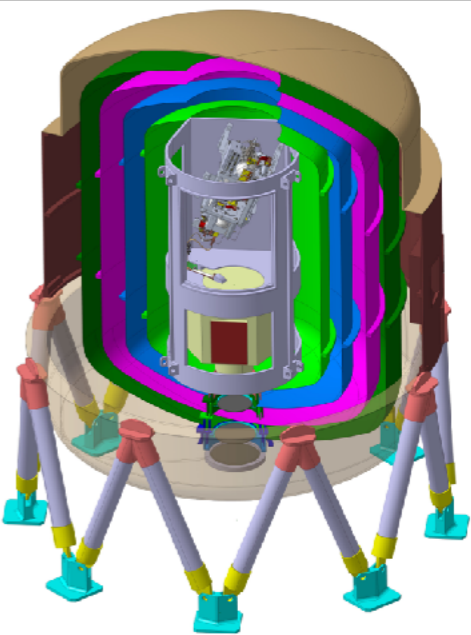
Optics	Wide Field Imager	X-ray Integral Field Unit
<p>Light-weight Si-pore optics</p>	<p>Active Pixel Sensors based on DEPFETs</p>	<p>Cryogenic imaging spectrometer, based on a large format of Transition Edge Sensors cooled at 50 mK with an active background shielding</p>
		
		
<p>ESA &amp; industry</p>	<p>Consortium led by MPE (K. Nandra), with other European partners and NASA</p>	<p>Consortium led by IRAP/CNES-F (D. Barret), with SRON-NL (J.W. den Herder), INAF/IAPS-IT (L. Piro) and other European partners, <b>NASA and JAXA.</b></p>

# Functional block diagram

microcalorimeters array

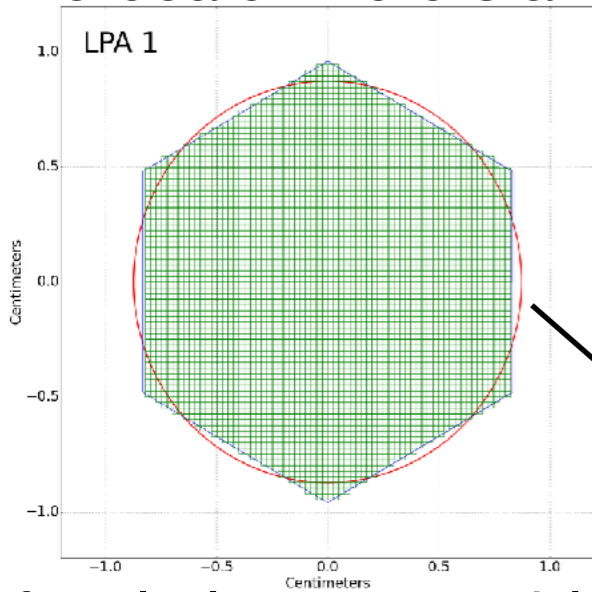

focal plane assembly

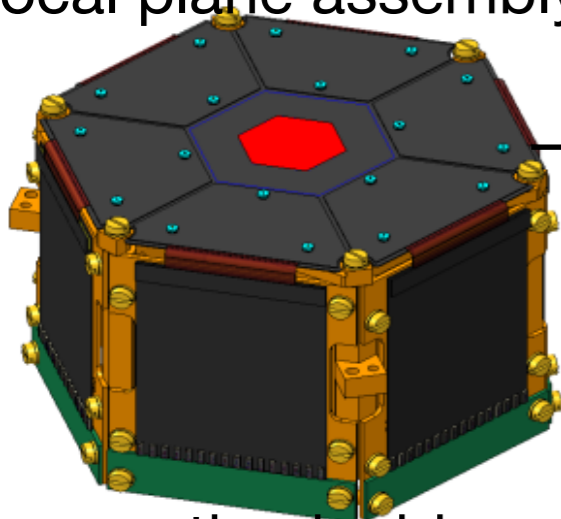

cryo anti coincidence

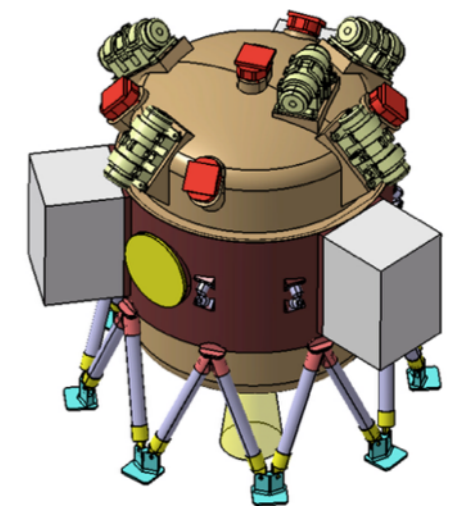
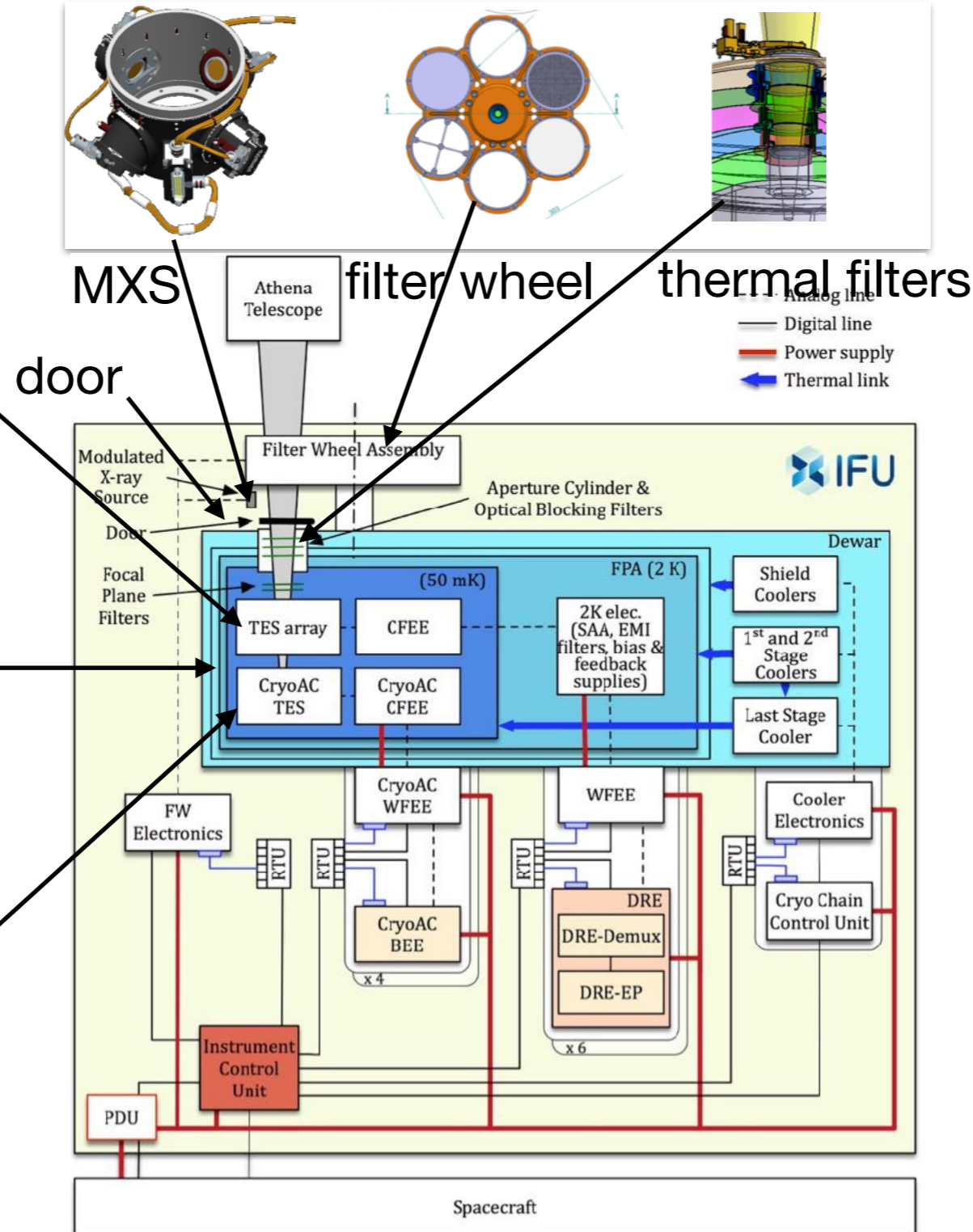
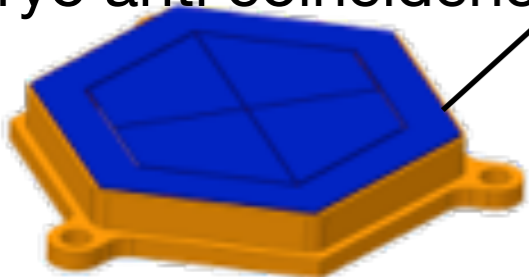

dewar

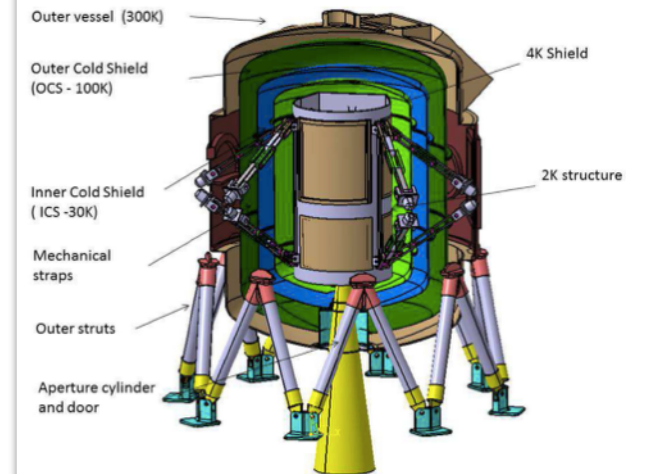

readout electronics

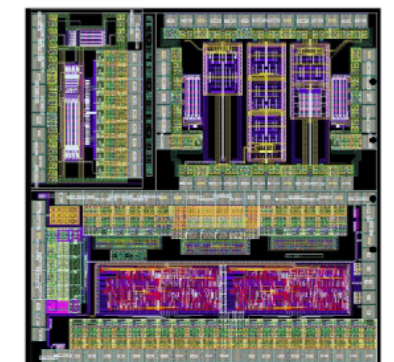



# Change of baseline cooling chain

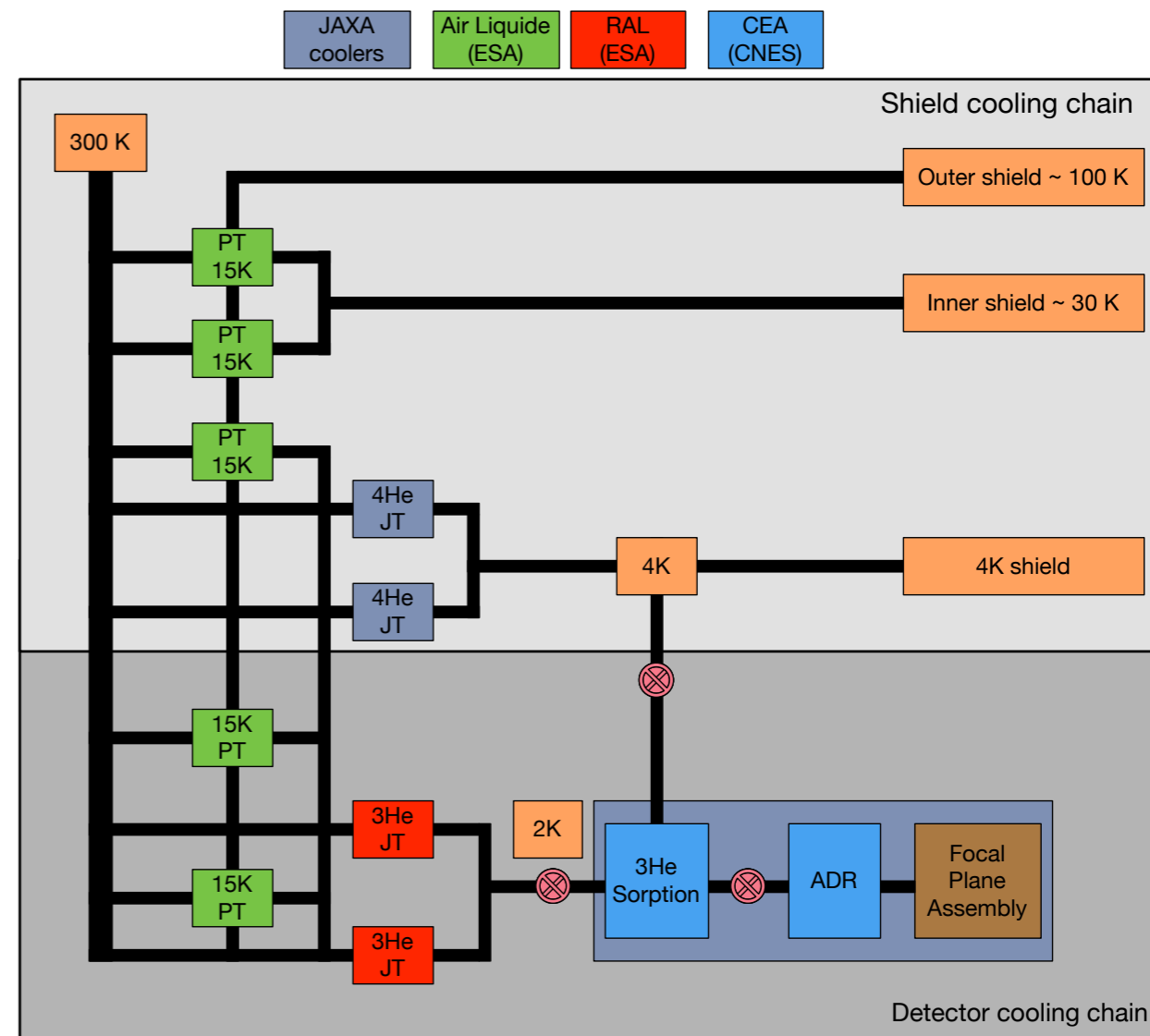
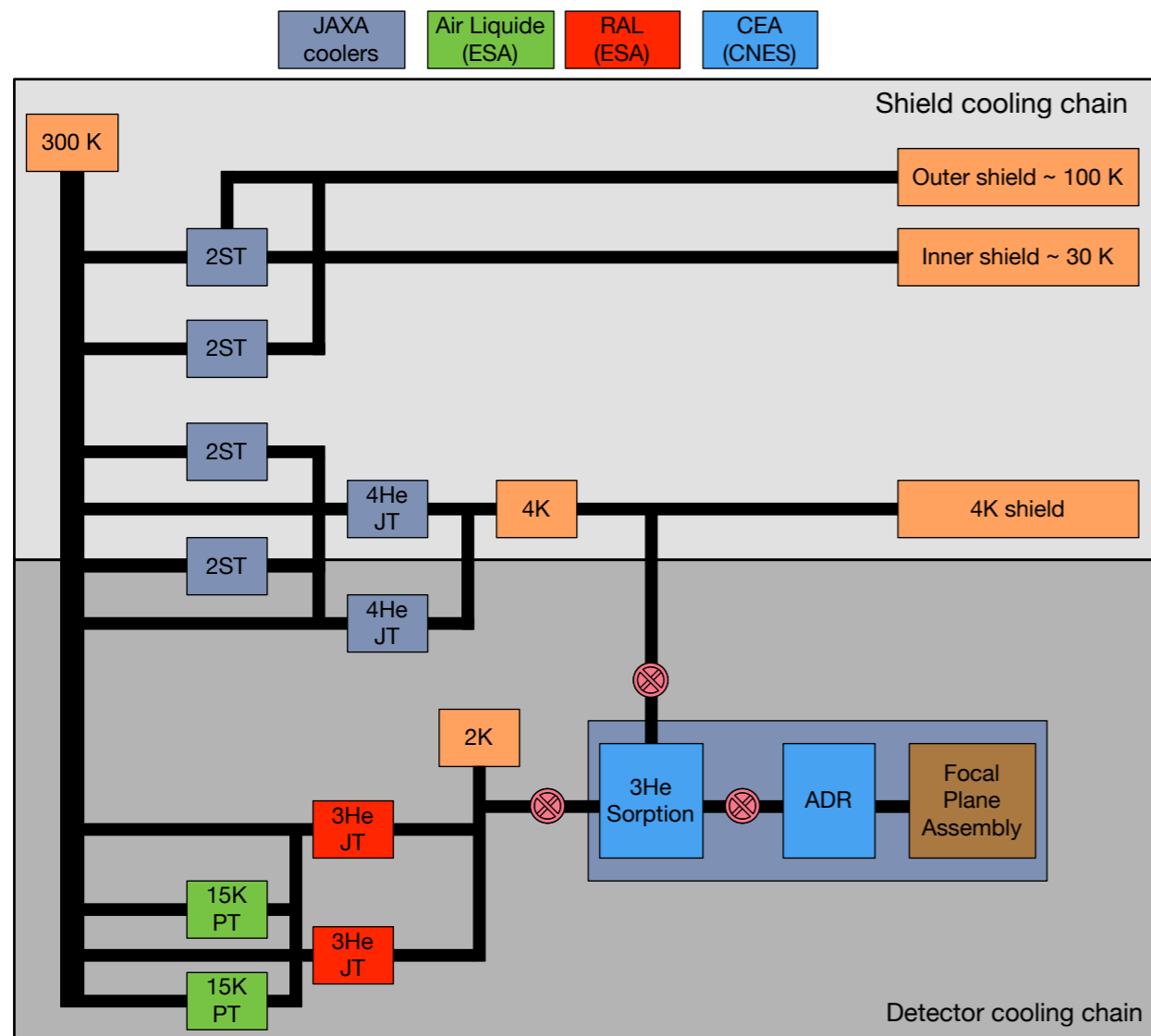

Courtesy of C. Daniel et al.

# Support of the CDF run on FPM

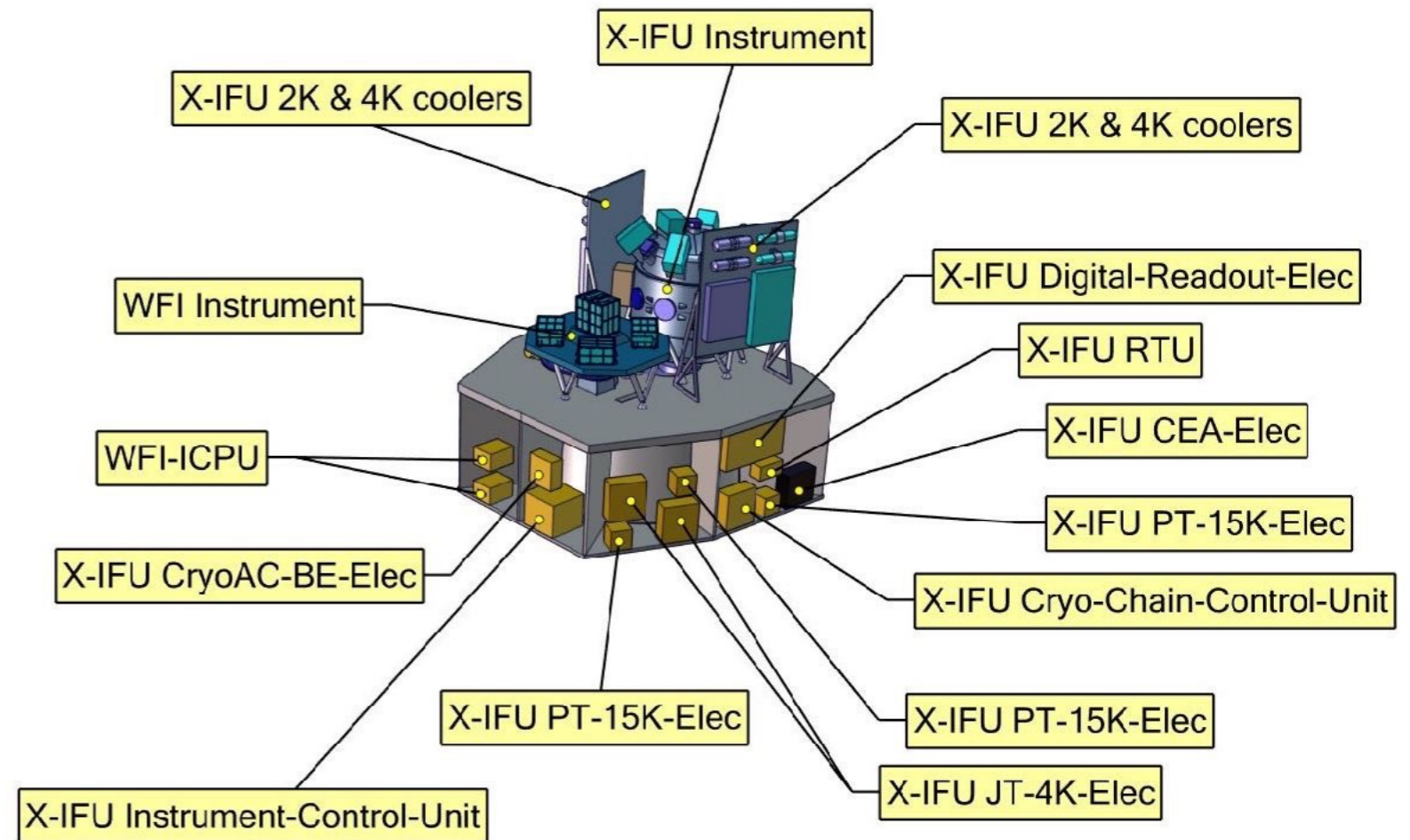
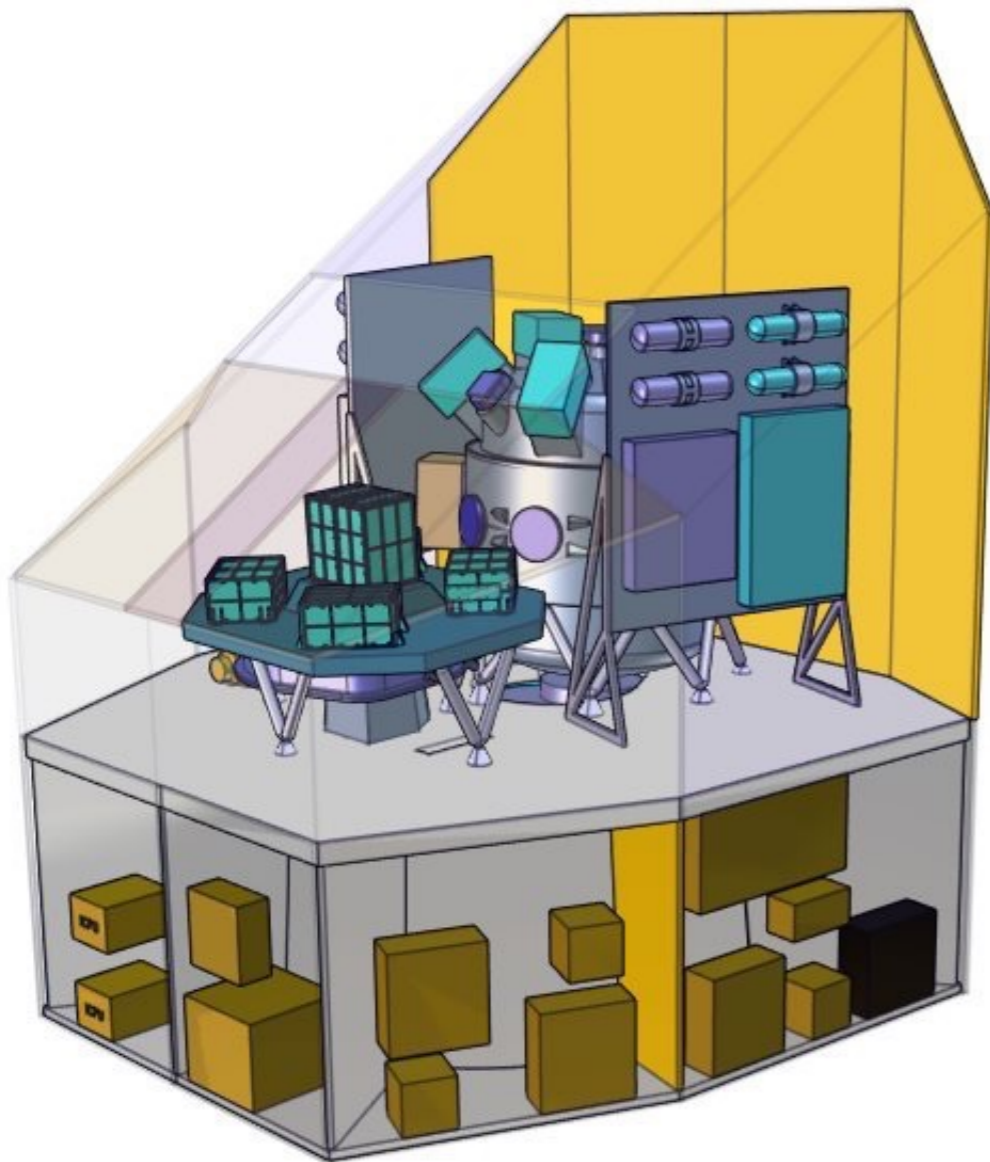

Courtesy of ESA

- Athena and the X-IFU are progressing smoothly through phase A - The delta MCR will lead to a baseline configuration for the overall system that will fit the 7 ton launch capability of Ariane 6
  - Joint optimization of the PL/SC components will certainly be needed
- International partner contributions to Athena (beyond those related to the P/L) need to be defined and agreed up and will clearly help in bringing the ESA CaC to within the cap
  - One option to be followed is the procurement of the PT coolers (or part of) for the revised cryogenic chain
- The NASA contribution to the X-IFU (TES array & expertise) is essential
  - Discussions on potential contributions to the X-IFU Instrument Science Center (part of the Athena SGS) should get started

# Hold on and thank you for your support

The wealth of information provided by such a spectrum, that will be measured on sub-arc minute scales enables in depth studies of the physical properties of the hot cluster gas (e.g. temperature, density, turbulence, bulk motion, abundance, . . . )

High-z GRB afterglows probing the ISM composition at  $z > 7-10$  and tracing the first generation of stars to understand cosmic re-ionization, the formation of the first seed black holes, and the dissemination of the first metals.

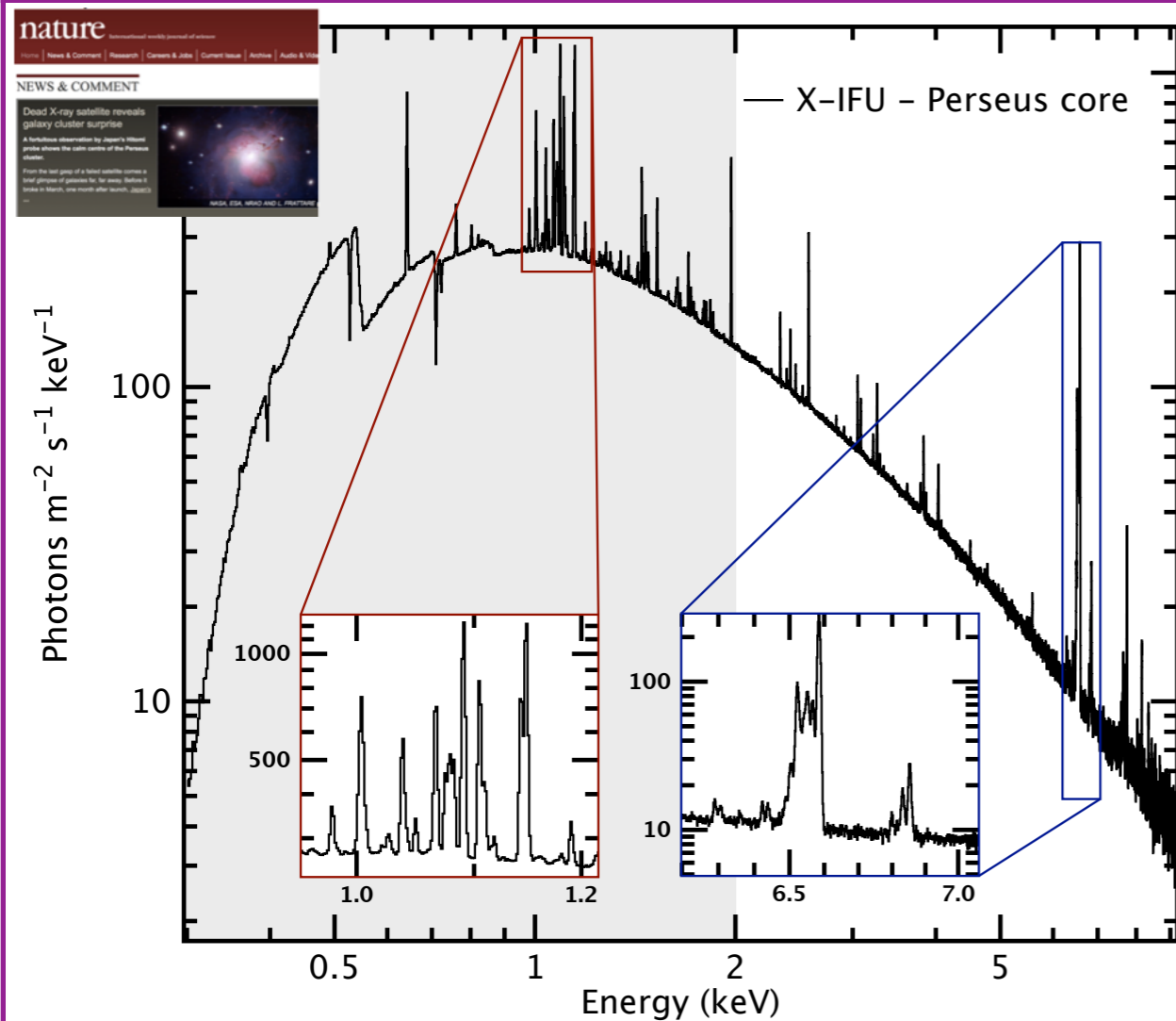

Perseus core X-IFU simulated spectrum based on Hitomi - Model  
courtesy of C. Pinto and A. Fabian

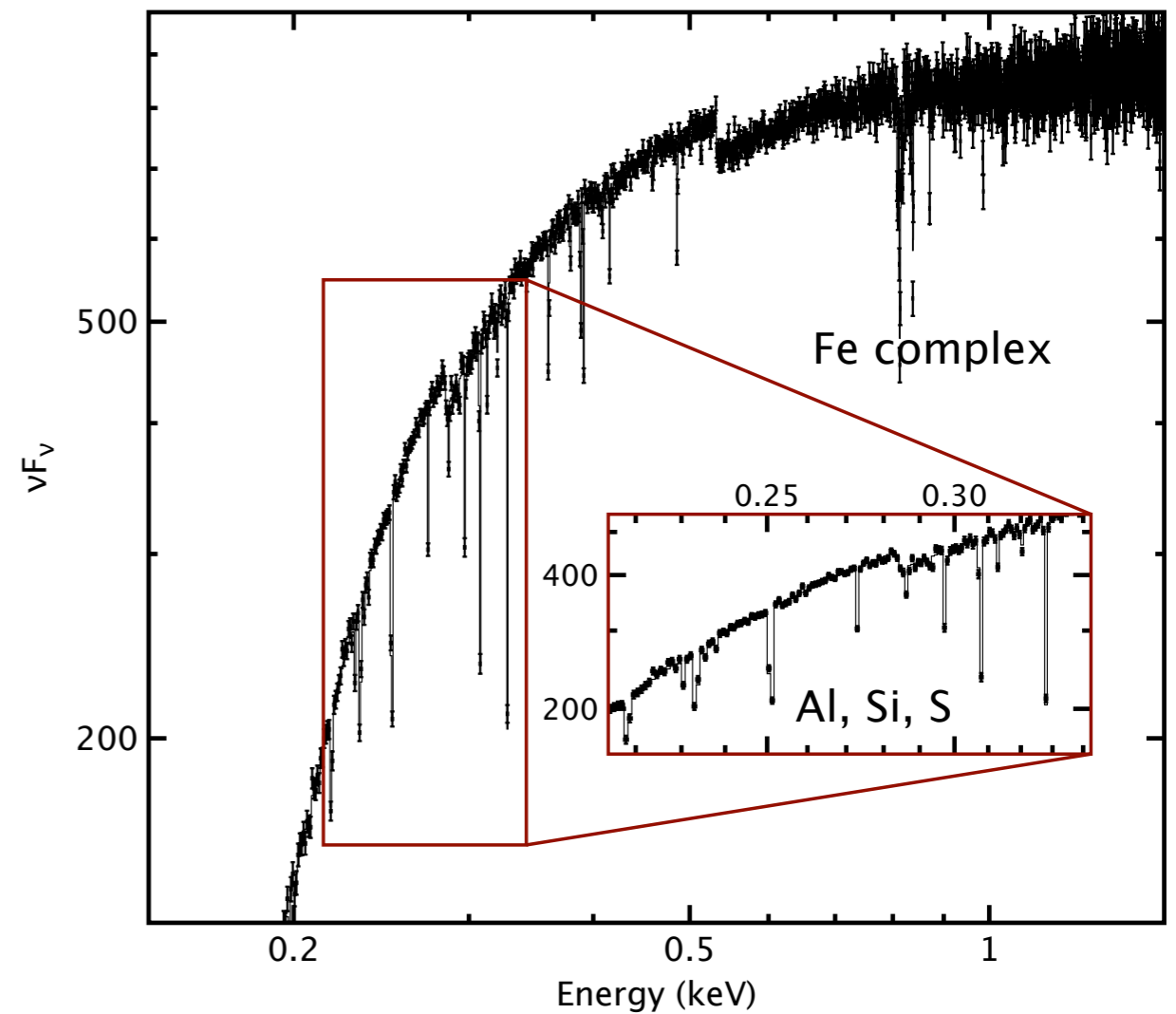

Barret et al. (2016) - Courtesy of L. Piro